



WLP & WCP Series



Mi-T-M Water Treatment Systems provide a better tomorrow by protecting our environment today.

Use one of these advanced water treatment systems to handle all of your water recycling and clarifying needs. The WLP and WCP Series are built with multiple components to remove free hydrocarbons from wash water by treating, filtering and reconditioning.

WLP Series

Advanced Wash Water Recycle Systems

WLP Series Recycle Systems Combine Enhanced Design With State-Of-The-Art Technology To Offer:

- Quality recycled wash water without common odor problems
- Easy operation and maintenance
- Poly skid is constructed of hardened polymer to be non-corrosive. It can also be easily lifted and moved with a forklift from all four sides.
- Easily accessible pumps
- CSA approved control panel which meets the requirements of the US and Canadian standards for an Industrial Control Panel



WLP-20-0M10

Mi-T-M's recycle systems are designed to remove free hydrocarbons and filter the water to be sent back through a pressure washer. The systems come standard with pH and ORP injection and are designed with corrosion-resistant stainless-steel tanks.



CSA listed NEMA-4 rated corrosion-proof control panel for safe and reliable operation



Hose connectors are clearly marked and designed for easy accessibility and quick installation



Recommended Mi-T-M Air Compressor AM1-HE02-05M for use with the auto-backwash models

AM1-HE02-05M
 4.2 CFM @ 90 PSI
 2.0 HP, 120V, 15.0A Electric Motor
 5-Gallon Twin Tank Receivers

MODEL NUMBER	FLOW RATE	MEDIA FILTER (CUSTOM MIX)	CARTRIDGE FILTER	CARBON FILTER (DEGASSED)	POWER REQUIREMENTS	AIR REQUIRED	DIMENSIONS (LxWxH)	SHIP WT.
WLP-08-0M10	0-8 GPM	350 lb.	100 sq. ft.	110 lb.	230V, 1Ø, 21.0A	-	6ft.x5ft.x52in.	1475 lb.
WLP-20-0M10	0-20 GPM	550 lb.	400 sq. ft.	110 lb.	230V, 1Ø, 25.0A	-	8ft.x5ft.x52in.	2435 lb.
WLP-20AB-0M11*	0-20 GPM	550 lb.	-	110 lb.	230V, 1Ø, 25.0A	60 to 100-PSI	8ft.x5ft.x52in.	2435 lb.
WLP-20AB-0M31*	0-20 GPM	550 lb.	-	110 lb.	230V, 3Ø, 13.0A	60 to 100-PSI	8ft.x5ft.x52in.	2435 lb.
WLP-30-0M10	0-30 GPM	500 lb.	400 sq. ft.	110 lb.	230V, 1Ø, 30.0A	-	8ft.x5ft.x52in.	2735 lb.
WLP-40-0M10	0-40 GPM	900 lb.	600 sq. ft.	165 lb.	230V, 1Ø, 30.0A	-	(2) 8ft.x5ft.x60in.	3200 lb.
WLP-40AB-0M11*	0-40 GPM	900 lb.	-	165 lb.	230V, 1Ø, 30.0A	60 to 100-PSI	7ft.x9ft.x60in.	3100 lb.
WLP-40AB-0M31*	0-40 GPM	900 lb.	-	165 lb.	230V, 3Ø, 17.0A	60 to 100-PSI	7ft.x9ft.x60in.	3100 lb.

*Auto-backwash models (air required 60 to 100-PSI)

230/208/460V 3-phase available on all models as options.

Accessories:

PART NUMBER	DESCRIPTION	FITS MODELS
32-0538	pH probe - Keeps the water at an appropriate pH level so the germicide is effective at killing bacteria and controlling odor	All models
32-0540	ORP probe - Measures and injects a germicide to control odor by killing odor-causing bacteria	All models
32-0693	pH probe (self-cleaning) - Keeps the water at an appropriate pH level so the germicide is effective at killing bacteria and controlling odor	All models
55-1887	Check valve, 2-inch - Holds prime in suction line	All models
AT-4007	Replacement air filter - Moisture trapping replacement filter	Auto-backwash models

Process & Flow Description

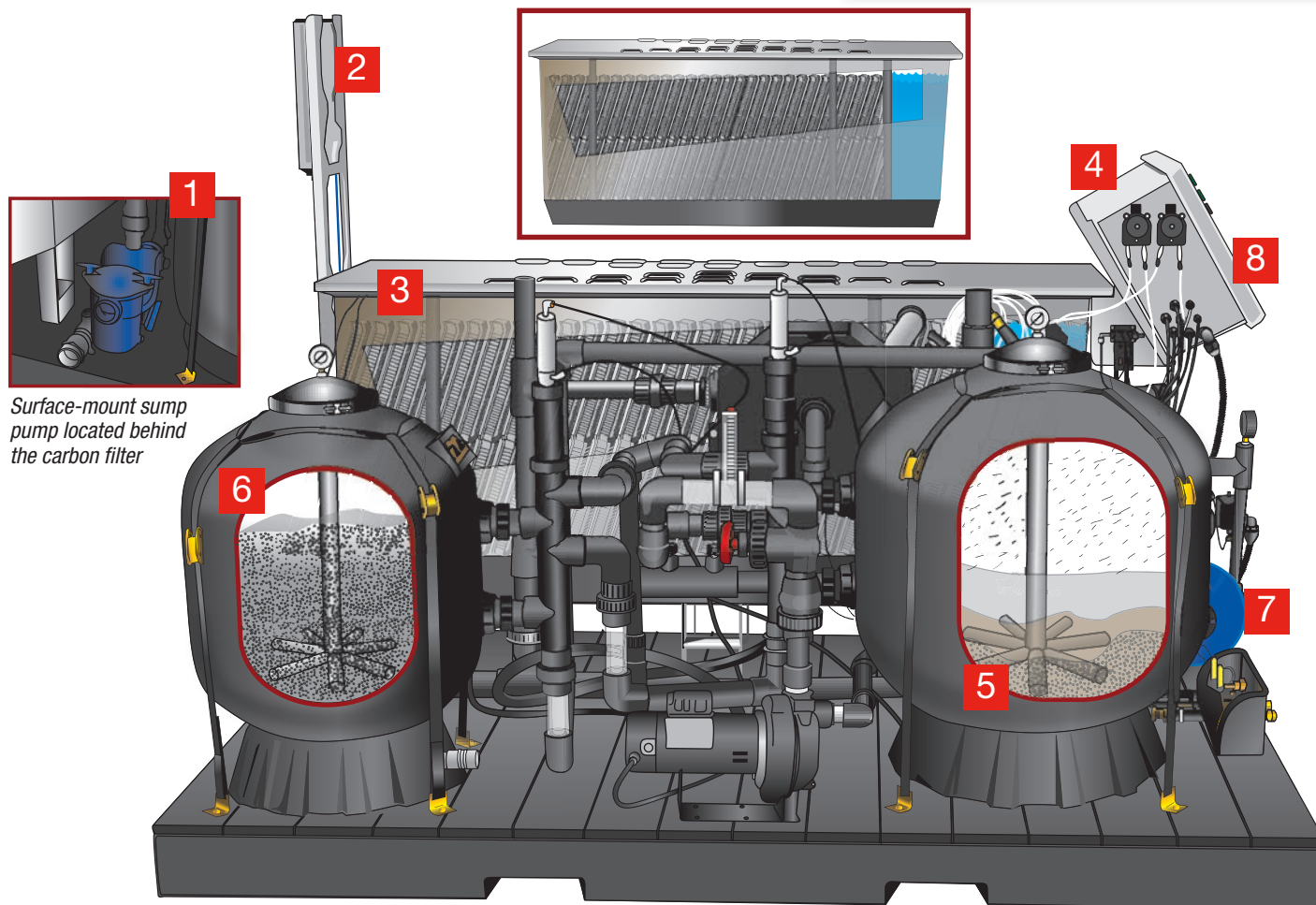

Surface-mount sump pump located behind the carbon filter

- 1. Surface-Mount Sump Pump** - Untreated wash water is introduced into the system via a 1.0 HP surface-mount sump pump, which is included with the system, located on the unit.
- 2. Corona Discharge Ozone System** - Wash water is injected with a high concentration of ozone via a corona discharge ozone injector system for a "quick kill" of live bacteria on contact. Ozone also breaks up emulsified oils, allowing them to coalesce and float to the top of the tank for separation into the oil decanter.
- 3. Advanced Oil/Water/Solids Separator** - As the water flows through the three-stage oil/water/solids separator, it changes directions countless times as the water is directed and redirected through four horizontal baffles and hundreds of square feet of honey-combed-shaped meshed oleophilic (oil-attracting) coalescing media. Mechanically emulsified oil particles are attracted from the water to the oleophilic media and float to the surface. Once on the surface, the oil is skimmed off into an oil decanter for easy disposal. Fine silt and particulates are dropped to the bottom of the sloped stainless-steel tank for easy flushing and disposal of the accumulated solids.
- 4. ORP/pH Controller** - For longer term control of bacteria, the ORP injection system automatically measures and injects a germicide to control odor by killing odor-causing bacteria. The automated pH control system keeps the water at an appropriate pH level so the germicide is effective at killing bacteria and controlling odor.
- 5. Customized Multi-Media Filter** - Once the water has been treated for oil and solids removal, it is then pushed through a customized multi-media filter which contains a special media blend to filter out particulates down to 25-microns.
- 6. Activated Carbon Filter** - The final treatment stage of the system occurs as the water is filtered through activated carbon which absorbs hydrocarbons, herbicides, pesticides, metals and dozens of other carbon-based constituents. Activated carbon also works as a polisher for treated water to remove chlorides.
- 7. Treated Water in Holding Tank** - Once the water is treated, it is pressurized where it will be ready for reuse at 30-PSI to 50-PSI.
- 8. Electrical Control Panel** - CSA listed NEMA-4 rated corrosion-proof control panel for safe and reliable operation.

Sample Equipment Wash Pad Application

Remote Box for Pressure Washer with Hose Reel and Wall Mount Bracket (#50-0196 and #13-0207A01)

HEG-3004-0E2G (Electric Powered Natural Gas Fired Hot Water Pressure Washer)

AM1-HE02-05M (Air Compressor for use with Auto-Backwash)

Model #WLP-20AB-0M11 Wash Water Recycle System

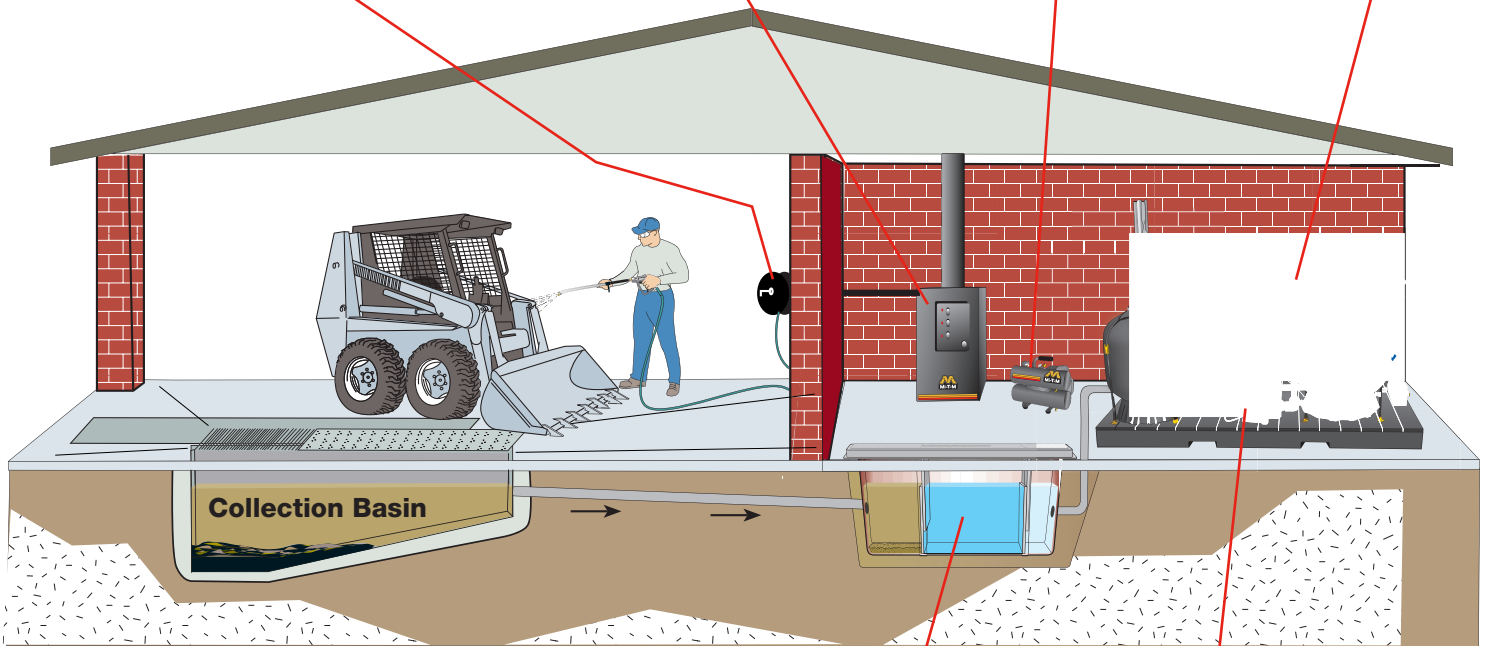

**Model #12-0074
3' x 9' Fiberglass
3-Stage Collection Pit**

**Model #3-0328
1.0 HP Surface-
Mount Sump Pump
Included with System**

The WLP Series is perfect for the following applications:

- Rental Yards
- Heavy Equipment Dealers
- Trucking Facilities
- Military Bases
- Truck Rental Fleets
- Diesel Repair Facilities
- Forklift Washing Operations
- Aircraft Maintenance and Restoration
- Shipyards
- Municipalities/State DOTs
- Oil Fields
- Engine Rebuilders and Manufacturers

The Importance of a Proper Pit System

Once equipment is washed, the untreated wash water flows into your pit system. A proper pit system for your application is the first step in proper wash water treatment and a critical element in any wash water recycle system.

Consult Mi-T-M Corporation or your local distributor to determine the pit system configuration that works best for your application.

Mi-T-M's recycle systems are designed to remove free hydrocarbons and filter the water to be sent back through a pressure washer. The systems come standard with pH and ORP injection and are designed for corrosion-resistance by utilizing polymer tanks and recycled-plastic skids.

WCP Series Clarifier Wash Water Recycle Systems

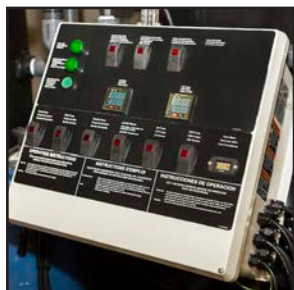

CSA listed NEMA-4 rated corrosion-proof control panel for safe and reliable operation



Hose connectors are clearly marked and designed for easy accessibility and quick installation



Recommended Mi-T-M Air Compressor AM1-HE02-05M for use with the auto-backwash models

AM1-HE02-05M
4.2 CFM @ 90 PSI
2.0 HP, 120V, 15.0A
Electric Motor
5-Gallon Twin Tank
Receivers

These Wash Water Recycle Systems Combine Enhanced Design With State-Of-The-Art Technology To Offer:

- Cone-shaped tank for easy handling of accumulated solids
- Quality recycled wash water without common odor problems
- Easy operation and maintenance
- Easily accessible pumps
- Heavy-duty, corrosive-resistant base for years of maintenance-free operation
- CSA approved control panel which meets the requirements of the US and Canadian standards for an Industrial Control Panel



WCP-30AB-0M30

MODEL NUMBER	FLOW RATE	CLARIFIER TANK	MEDIA FILTER	CARTRIDGE FILTER	CARBON FILTER	OIL COALESCING AREA	OZONE GENERATOR	POWER REQUIREMENTS	DIMENSIONS (LxWxH)	SHIP WT.
WCP-10-0M10	0-10 GPM	300 gallons	250 lb.	100 sq. ft.	110 lb.	275 sq. ft.	6 grams/day	230V, 1Ø, 30.0A	5x8x9ft.	2400 lb.
WCP-10AB-0M10*	0-10 GPM	300 gallons	350 lb.	-	110 lb.	275 sq. ft.	6 grams/day	230V, 1Ø, 30.0A	5x8x9ft.	2400 lb.
WCP-10AB-0M30*	0-10 GPM	300 gallons	350 lb.	-	110 lb.	275 sq. ft.	6 grams/day	230V, 3Ø, 15.0A	5x8x9ft.	2400 lb.
WCP-20-0M10	0-20 GPM	600 gallons	350 lb.	400 sq. ft.	165 lb.	425 sq. ft.	12 grams/day	230V, 1Ø, 30.0A	6x8x9ft.	2500 lb.
WCP-30-0M10	0-30 GPM	600 gallons	900 lb.	400 sq. ft.	165 lb.	425 sq. ft.	12 grams/day	230V, 1Ø, 35.0A	7x9x9ft.	3470 lb.
WCP-30AB-0M10*	0-30 GPM	600 gallons	900 lb.	-	165 lb.	425 sq. ft.	12 grams/day	230V, 1Ø, 35.0A	7x9x9ft.	3470 lb.
WCP-30AB-0M30*	0-30 GPM	600 gallons	900 lb.	-	165 lb.	425 sq. ft.	12 grams/day	230V, 3Ø, 20.0A	7x9x9ft.	3470 lb.

*Auto-backwash models (air required 60 to 100-PSI)

230/208/460V 3-phase available on all models as options.

Options:

PART NUMBER	DESCRIPTION	FITS MODELS
WX-0039	Pinch valve assembly - Pinch valve, bladder style (used on cone-bottom tanks), 2-in., 120VAC, single phase	Manual backwash models
WX-0123	460V, 3Ø - Upgrades 230V model to operate at 460V	WCP-10AB-0M30

Process & Flow Description

- Surface-Mount Sump Pump** - Untreated wash water is introduced into the system via a 1.0 HP surface-mount sump pump, which is included with the system, located on the unit.
- Clarifier Oil/Water/Solids Separator** - As the water flows through the cone-shaped oil/water/solids separator, it changes directions countless times as the water is directed and redirected through cone baffles and hundreds of square feet of oleophilic (oil-attracting) coalescing media. Mechanically emulsified oil particles are attracted from the water to the oleophilic media and float to the surface. Once on the surface, the oil is skimmed off into an oil decanter for easy disposal. Fine silt and particulates are dropped to the bottom of the sloped stainless-steel tank for easy flushing and disposal of the accumulated solids.
- Corona Discharge Ozone System** - Water in the cone tank is injected with a high concentration of ozone via a corona discharge ozone injector system, tiny bubbles saturate the water in the cone tank, killing live bacteria instantly on contact. Ozone also breaks up emulsified oils, allowing them to coalesce and float to the top of the tank for separation into the oil decanter.
- Oil Decanter** - Oil skimmed from the surface of the clarifier tank is captured in a conveniently located oil decanter where oil can be removed easily for appropriate disposal.
- Sludge Box** - Solids from the wastewater stream settle at the base of the clarifier tank. With the opening of a single valve, solids are easily dropped into a bag filter in the solids separation chamber for effective capture and easy disposal. The bag filter is suspended on a dewatering tray with drainage returning to the in-ground collection pits.
- Customized Multi-Media Filter** (located at the back of the skid) - Once the water has been treated for oil and solids removal, it is then pushed through a customized multi-media filter which contains a special media blend to filter out particulates down to 25-microns.
- Reusable Polyester Filter** - Once the larger particulates are removed, the water is then filtered through hundreds of square feet of reusable polyester 30-micron filters. (Not used on the auto-backwash models)
- Activated Carbon Filter** - The final treatment stage of the system occurs as the water is filtered through activated carbon which absorbs hydrocarbons, herbicides, pesticides, metals and dozens of other carbon-based constituents. Activated carbon also works as a polisher for treated water to remove chlorides.
- ORP/pH Controller** - For longer term control of bacteria, the ORP injection system automatically measures and injects a germicide to control odor by killing odor-causing bacteria. The automated pH control system keeps the water at an appropriate pH level so the germicide is effective at killing bacteria and controlling odor.
- Treated Water in Holding Tank** - Once the water is treated, it is pressurized where it will be ready for reuse at 30-PSI to 50-PSI.
- Electrical Control Panel** - CSA listed NEMA-4 rated corrosion-proof control panel for safe and reliable operation.

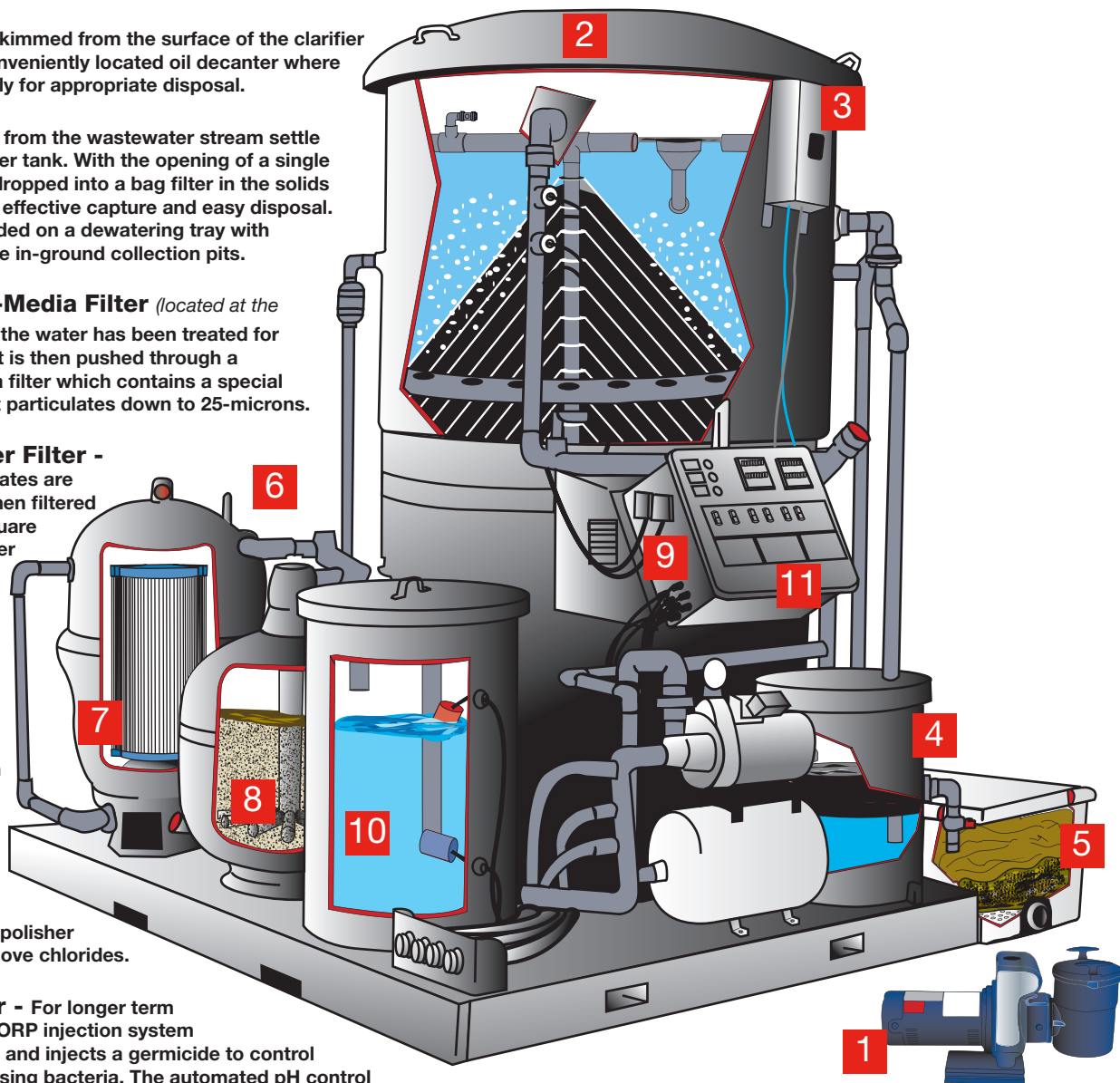

Sample Equipment Wash Pad Application

WC Series Hose and Reel (#15-2001 and #50-2001)

Remote Box for Pressure Washer with Hose Reel and Wall Mount Bracket (#50-0196 and #13-0207A01)

Model #WCP-20-0M10 Clarifier Wash Water Recycle System

HEG-3004-0E2G (Electric Powered Natural Gas Fired Hot Water Pressure Washer)

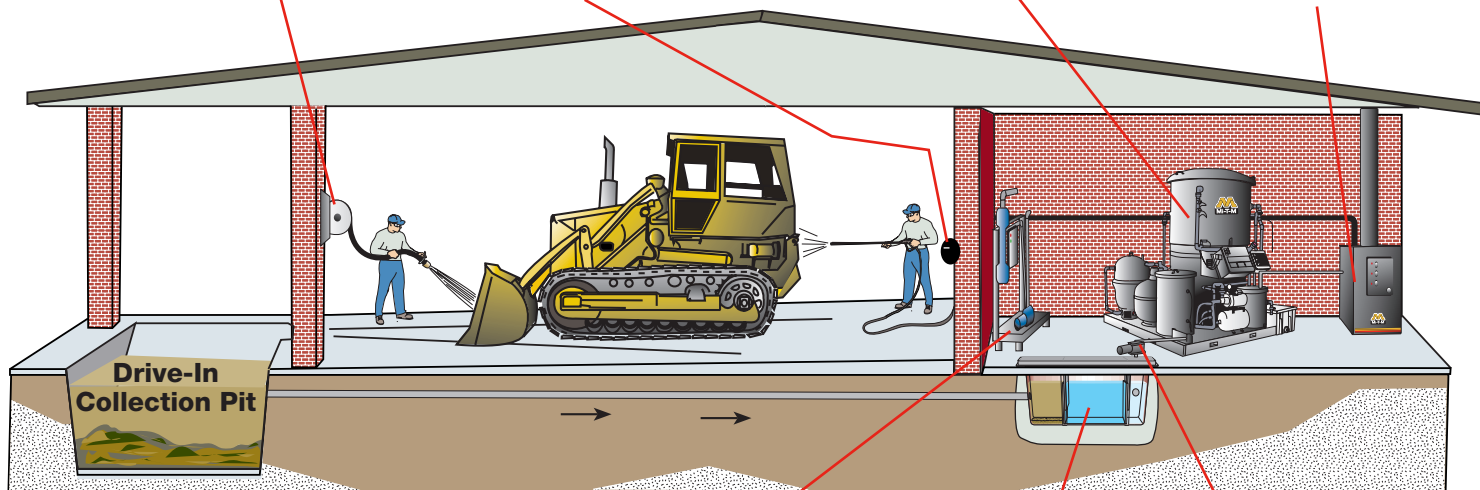

Model #WC-100-0ME3 Water Cannon

Model #12-0074 3' x 9' Fiberglass 3-Stage Collection Pit

Model #3-0328 1.0 HP Surface-Mount Sump Pump Included with System

The WCP Series is perfect for the following applications:

- Rental Yards
- Golf Courses
- Heavy Equipment Dealers
- Trucking Facilities
- Military Bases
- Truck Rental Fleets
- Diesel Repair Facilities
- Forklift Washing Operations
- Aircraft Maintenance and Restoration
- Shipyards
- Municipalities/State DOTs
- Oil Fields
- Engine Rebuilders and Manufacturers

The Importance of a Proper Pit System

Once equipment is washed, the untreated wash water flows into your pit system. A proper pit system for your application is the first step in proper wash water treatment and a critical element in any wash water recycle system.

Consult Mi-T-M Corporation or your local distributor to determine the pit system configuration that works best for your application.

WCPB Series

- Special-build model
- Mi-T-M WCPB Series allows the end user to switch from a mechanical filtration unit to a biological unit depending on certain factors. The end user may change the unit depending on the time of year, temperature, contaminants in water pH or other factors.
- Contact Mi-T-M Corporation or your local distributor for more information.



WLP & WCP Series Accessories

Replacement Filter Elements

PART NUMBER	DESCRIPTION	FITS MODELS
19-0263	Filter - Replacement filter for #19-0627, 30-micron, 150 sq. ft., 3 filters needed	WLP-08 & WCP-10
19-0264	Filter - Replacement filter for #19-0630, 30-micron, 400 sq. ft., 3 filters needed	WLP-20, WLP-30, WCP-20 & WCP-30
19-0265	Filter - Replacement filter for #19-0631, 30-micron, 500 sq. ft., 3 filters needed	WLP-40
19-0274	Filter - Replacement filter for #19-0632, 30-micron, 100 sq. ft., 1 filter needed	WLP-08 & WCP-10



19-0265, filter

Replacement Media

PART NUMBER	DESCRIPTION
33-0302	Activated carbon - Order per pound
33-0303	Gravel #3 - Order per pound
33-0304	Garnet #12 - Order per pound
33-0305	Garnet #50 - Order per pound
33-0306	Filter ag - Order per pound
33-0318	Organoclay - Custom media, order per pound
33-0403	Garnet #80 - Order per pound
33-0449	Large funnel - Funnel helps you load media
33-0450	Zeolites - Custom media, best for red clay, 50 lb. bag, order per pound

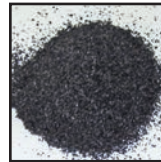

Activated Carbon



Gravel #3



Garnet #12



Garnet #50

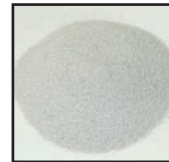

Filter Ag

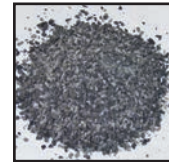

Organoclay



Garnet #80



Performance Under Pressure.®

Mi-T-M Corporation
50 Mi-T-M Drive
Peosta, IA 52068
800-553-9053
563-556-1235 fax
corp@mitm.com
www.mitm.com

Distributed by: