



**PROFESSIONAL  
18 INCH ROTARY SURFACE CLEANER**

***AW-7020-8000***

**OPERATING INSTRUCTIONS AND  
PARTS LIST**



**CAUTION**

**RISK OF INJURY! READ MANUAL BEFORE OPERATING!  
THIS MANUAL IS AN IMPORTANT PART OF THE CLEANER AND MUST  
REMAIN WITH THE UNIT WHEN YOU SELL OR RENT IT!**

# TABLE OF CONTENTS

<b>INTRODUCTION</b> .....	<b>3</b>
<b>SPECIFICATIONS</b> .....	<b>4</b>
<b>IMPORTANT SAFETY WARNINGS</b> .....	<b>5-7</b>
RISK OF INJECTION OR SEVERE CUTTING INJURY .....	5
RISK OF BURNS .....	6
RISK OF BODILY INJURY .....	6-7
<b>FEATURES</b> .....	<b>8</b>
<b>INSTALLATION &amp; PREPARATION</b> .....	<b>9-10</b>
NOZZLE SELECTION & INSTALLATION .....	9
UNIT ASSEMBLY .....	9
SET-UP .....	9
SURFACE PREPARATION .....	9
PRE-START INSPECTION PROCEDURES .....	10
<b>OPERATION</b> .....	<b>12</b>
START-UP .....	12
SHUT-DOWN .....	12
<b>TROUBLESHOOTING</b> .....	<b>13</b>
<b>PARTS LIST</b> .....	<b>14-17</b>
<b>WARRANTY</b> .....	<b>19</b>

## **WARNING**

 **WARNING:** This product can expose you to chemicals including Lead, which is known to the State of California to cause cancer and birth defects or other reproductive harm. For more information go to [www.P65Warnings.ca.gov](http://www.P65Warnings.ca.gov)

# INTRODUCTION

Congratulations on the purchase of your new Mi-T-M Rotary Surface Cleaner! You can be assured this Cleaner was constructed and designed with quality and performance in mind. Each component has been rigorously tested to ensure the highest level of acceptance.

Your Rotary Surface Cleaner is equipped with a heavy duty high pressure swivel with the versatility of using this Cleaner in both cold and hot water applications. Simply connect the rotary surface Cleaner to your pressure washer, pull the trigger and walk behind for fast and efficient cleaning!

This manual was compiled for your benefit. The contents of this manual are based on the latest product information available at the time of publication. Mi-T-M reserves the right to make changes in price, color, material, equipment, specifications or models at any time without notice.

## ! IMPORTANT !

These paragraphs are surrounded by a "SAFETY ALERT BOX". This box is used to designate and emphasize Safety Warnings that must be followed when operating this Rotary Surface Cleaner. Accompanying the safety warnings are "signal words" which designate the degree or level of hazard seriousness. The "signal words" used in this manual are as follows:

**DANGER:** Indicates an imminently hazardous situation which, if not avoided, WILL result in death or serious injury.

**WARNING:** Indicates a potentially hazardous situation which, if not avoided, COULD result in death or serious injury.

**CAUTION:** Indicates a potentially hazardous situation which, if not avoided MAY result in minor or moderate injury.



The symbols set to the left of this paragraph are "Safety Alert Symbols". These symbols are used to call attention to items or procedures that could be dangerous to you or other persons using this equipment.

**ALWAYS PROVIDE A COPY OF THIS MANUAL TO ANYONE USING THIS EQUIPMENT. READ ALL INSTRUCTIONS IN THIS MANUAL AND ANY INSTRUCTIONS SUPPLIED BY MANUFACTURERS OF SUPPORTING EQUIPMENT BEFORE OPERATING THIS UNIT AND ESPECIALLY POINT OUT THE "SAFETY WARNINGS" TO PREVENT THE POSSIBILITY OF PERSONAL INJURY TO THE OPERATOR.**

Unbox the unit and inspect for signs of obvious or concealed freight damage. Be sure that all damaged parts are replaced and the mechanical problems are corrected prior to the operation of the cleaner. Write in the serial number in the space provided below.

**SERIAL NUMBER** \_\_\_\_\_

If you have questions, contact your Customer Service Representative at 800-553-9053.

Please have the following information available for all service calls:

1. Model Number
2. Serial Number
3. Date and Place of Purchase

# SPECIFICATIONS

Operating Pressure (PSI/ BAR)	2000-4000/ 138-276
Water Volume (GPM/ IPM)	3.0-10.0/ 11.36- 37.85
Maximum Temperature (°F/ °C)	212°/ 100°
Maximum RPM	2500
Unit Net Weight (lbs./ Kg)	19/ 8.62
Unit Net Dimensions (IN/ CM)	L18.75 x W18.75 x H71.25/ L47.6 x W47.6 x H181.0
Unit Shipping Weight (lbs./ Kg)	25/ 11.34
Unit Shipping Dimensions (IN/ CM)	L35.0 x W19.75 x H10.25/ L88.9 x W50.2 x H26.0



## SAFETY WARNINGS



When using this product, basic precautions should always be observed, including the following:  
**READ ALL SAFETY WARNINGS BEFORE USING ROTARY SURFACE CLEANER**

HAZARD	POTENTIAL CONSEQUENCE	PREVENTION
<p data-bbox="111 212 333 282"><b>RISK OF INJECTION OR SEVERE CUTTING INJURY</b></p> 	<p data-bbox="348 207 625 282">Serious injury or death could occur from high pressure spray penetrating the skin.</p> <p data-bbox="355 1357 591 1430">Do not make repairs or adjustments while unit is running.</p>	<p data-bbox="639 212 1008 277">Keep clear of nozzle and spray! Never put your hand, fingers or body directly over the spray nozzle.</p> <p data-bbox="639 302 1001 367">Never point the high pressure discharge spray at yourself or anyone else.</p> <p data-bbox="639 391 961 435">This product is to be used only by trained operators.</p> <p data-bbox="639 459 1008 503">Always keep operating area clear of all persons.</p> <p data-bbox="639 527 1001 571">DO NOT allow children to operate this unit.</p> <p data-bbox="639 596 1008 816">If an accident does occur, and the spray appears to have penetrated the skin, <b>SEEK EMERGENCY MEDICAL CARE. DO NOT TREAT AS A SIMPLE CUT!</b> Be prepared to tell a physician exactly what kind of cleaning agents you were using by reading the Detergent Label and the Material Safety Data Sheet (MSDS) provided with your detergent.</p> <p data-bbox="639 841 1008 1019">High pressure hoses should be inspected daily for signs of wear. If evidence of failure exists, promptly replace all suspect hoses to prevent the possibility of injury from the high pressure spray. If a hose or fitting is leaking, <b>NEVER PLACE YOUR HAND DIRECTLY ON THE LEAK.</b></p> <p data-bbox="639 1044 1008 1198">Before using rotary surface cleaner, or when quick connecting high pressure hoses, be certain the "collar" on the female quick connect is locked securely to prevent accidental discharge and that all quick coupler fittings are secure.</p> <p data-bbox="639 1222 1001 1336">NEVER operate the gun with the trigger wired in the open position. To prevent accidental discharge, the trigger gun should be securely locked when not in use.</p> <p data-bbox="639 1360 1008 1557">Before removing the spray nozzle or servicing the unit, <b>ALWAYS</b> shut off the unit and trigger the gun to release trapped pressure. (Even after you shut off the unit, there is high pressure water left in the unit until you release it by triggering the gun.) Allow the unit to cool down and service in a clean, dry, flat area.</p>





## SAFETY WARNINGS



READ ALL SAFETY WARNINGS BEFORE USING ROTARY SURFACE CLEANER

HAZARD	POTENTIAL CONSEQUENCE	PREVENTION
<p data-bbox="168 185 344 233"><b>RISK OF BODILY INJURY</b></p> 	<p data-bbox="385 185 632 233">Injury may occur from the rotary surface cleaner.</p>	<p data-bbox="657 185 1025 354">ALWAYS hold on firmly to the handles of the Rotary Surface Cleaner when operating the unit. Failure to do so can cause the Cleaner to move dangerously. To prevent accidental discharge, the trigger gun should be securely locked when not in use.</p> <p data-bbox="657 376 1004 513">Always wear eye and ear protection when using the Rotary Surface Cleaner. Other protective clothing such as a rubber suit, gloves, respirator, etc., may be necessary when using detergents.</p> <p data-bbox="657 535 966 584">Never make adjustments on the machine while in operation.</p> <p data-bbox="657 607 1019 711">DO NOT leave pressurized unit unattended. Shut off the pressure washer and release trapped pressure before leaving.</p> <p data-bbox="657 734 1019 805">Know how to stop the Rotary Surface Cleaner. Be thoroughly familiar with controls.</p>

**!SAVE THESE INSTRUCTIONS!**

# FEATURES

1. Box.
2. Insert.
3. Insert.
4. Cover Assembly.
5. Clevis Pin.
6. Bridge Pin.
7. Handle-Lower.
8. Clevis Pin.
9. Handle-Upper.

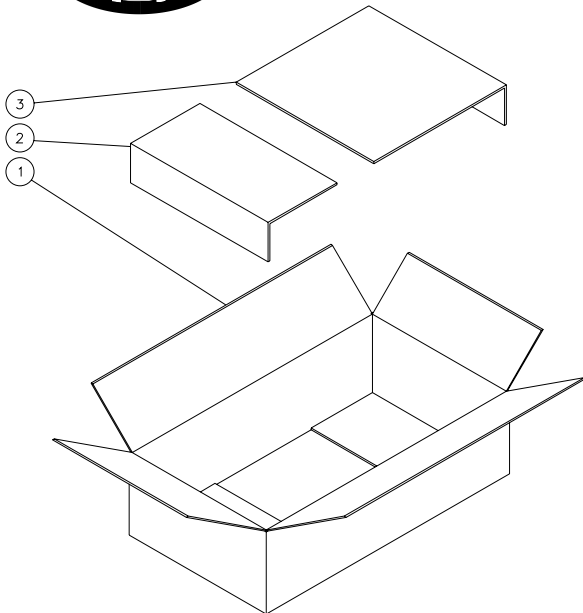
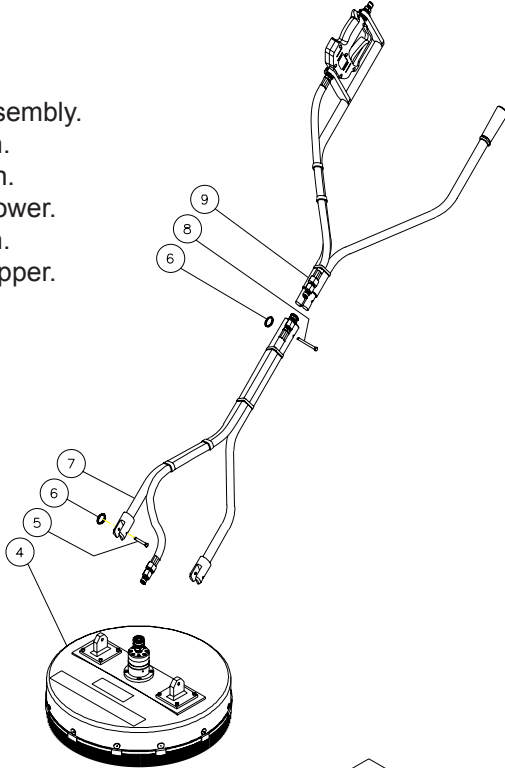



# INSTALLATION & PREPARATION

## NOZZLE SELECTION & INSTALLATION:

1. Your Rotary Surface Cleaner will come installed with one set of 2502.5 nozzles.
  - a. The minimum orifice size to be used in your Rotary Surface Cleaner is half that which is being used in your pressure washer. Example: If your pressure washer uses a size 5 orifice, you will need to use a size 2.5 orifice in your Rotary Surface Cleaner. (Two nozzles are inserted in the Rotary Surface Cleaner, therefore; two nozzles x size 2.5 orifice = size 5 orifice.)
  - b. The nozzles being used should have a 15°-25° spray pattern; anything less than a 15° spray pattern can damage the area being cleaned. Anything more than 25° may not allow the bar to rotate.
2. Nozzles should be screwed into the rotating bar. The spray fan should be parallel to the Rotating Bar. (See figure at right.)

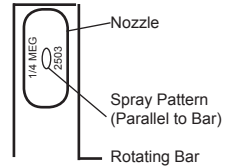

## UNIT ASSEMBLY:

1. Line up the holes on the lower part of handle (7) with the holes on the cover assembly (4).
2. Insert the clevis pins (5) through the handle and cover holes and attach to the bridge pins (6).
3. Attach the upper handle (9) by lining up the hole in the upper and lower handle. Push the clevis pin (8) through the aligned hole and attach to the bridge pin (6).
4. Quick connect the Rotary Surface Cleaner hose assembly to the handle center and to the swivel located on the unit base.

## SET-UP:

1. Locate the high pressure discharge hose on your pressure washer and ensure it is securely connected to the water outlet of the pressure washer. Quick connect the other end of the high pressure discharge hose to the gun on the Rotary Surface Cleaner.
2. Connect the water supply hose, one end to your pressure washer, the other end to a pressurized water supply.

## SURFACE PREPARATION:

1. Clear any loose debris from the area to be cleaned.
2. Never attempt to clean surface with objects that protrude from the surface being cleaned. Striking any raised obstacle during operation will damage machine. If contact does occur and results in vibration when operating machine, STOP and replace spray bar.



### CAUTION

**Risk of Injury or damage to machine!!**  
**NEVER OPERATE THE UNIT IF IT BEGINS TO VIBRATE!**  
**Shutdown the unit and tighten the rotating bar, bolts and fittings.**

# INSTALLATION & PREPARATION

## PRE-START INSPECTION PROCEDURES:

1. Inspect Rotary Surface Cleaner before each use. Tighten rotating bar, bolts and fittings as needed.
2. Ensure all connections are secure. Turn the water supply completely "ON". (DO NOT START PRESSURE WASHER!)
3. Inspect hoses for kinking, cut or leaks. If found, DO NOT USE HOSE! Replace damaged hoses before starting.
4. Unlock the trigger gun and squeeze the trigger. Water will begin flowing from the nozzles of the Surface Cleaner. Ensure nozzles are not clogged and spray pattern is not erratic. Change nozzles before proceeding if problems exist.
5. Be sure that all damaged parts are replaced and that the mechanical problems are corrected prior to operation. If you need service, contact an Authorized Service Center.



**END OF PREPARATION INSTRUCTIONS**





**THE FOLLOWING CONTAINS OPERATING AND MAINTENANCE INSTRUCTIONS.**

**DO NOT ATTEMPT TO OPERATE THIS ROTARY SURFACE CLEANER UNTIL YOU HAVE READ AND UNDERSTOOD ALL SAFETY WARNING AND INSTRUCTIONS LISTED IN THIS MANUAL.**

**INCORRECT OPERATION OF THIS UNIT CAN CAUSE SERIOUS INJURY!!**

**DO NOT ALTER OR MODIFY THIS EQUIPMENT IN ANY MANNER!**

# OPERATION

## START-UP:

1. Lock the trigger gun on the Rotary Surface Cleaner in the "OFF" position (move the lever on the gun handle to a 90° angle so it rests against the handle grip).
2. Ensure all connections are secure.
3. Unlock the trigger gun and squeeze the trigger while starting the Pressure Washer.
4. Water will begin flowing from the nozzles of the Surface Cleaner. Ensure nozzles are not clogged and spray pattern is not erratic. Turn the pressure washer and water supply off and change nozzles before proceeding if problems exist.
5. Walk slowly behind the unit, cleaning as you go. If striping occurs, slow down the pace. Do not allow machine to remain stationary on soft surfaces such as wood.
6. Check "weep holes" on top of the swivel periodically. Water will seep slowly. If it shoots out, shut-down the unit and replace seals and/or main seal.



## **CAUTION**

**Risk of Injury or damage to machine!!**

**NEVER OPERATE THE UNIT IF IT BEGINS TO VIBRATE!**

**Shutdown the unit and tighten the rotating bar, bolts and fittings.**

## SHUT-DOWN:

1. Turn the Pressure Washer off.
2. Turn the water supply off.
3. Squeeze the trigger gun to relieve water pressure.
4. Disconnect and drain the water hose and wipe down unit. Store unit in a non-freezing environment.

## TROUBLESHOOTING

PROBLEM	PROBABLE CAUSE	REMEDY
Inadequate cleaning power.	Not enough PSI from pressure washer.	Ensure unit produces a minimum 2000 PSI. Most effective cleaning range is 2500-4000 PSI.
	Inadequate water supply.	Turn water supply completely "ON" and/ or clean water filter on pressure washer. Ensure unit produces a minimum of 3.0 GPM.
	Engine RPM on pressure washer is too low.	Increase throttle.
	Nozzle obstructed or worn.	Clean or replace as necessary.
	Incorrect nozzle orifice size.	Insert correct nozzle.
Rotating bar will not rotate.	Seal has drag.	Allow for break-in period.
	Snap ring dislodged.	Do not use! Contact your Customer Service.
	Seal malfunction.	Do not use! Contact your Customer Service.
	Bearing failure.	Do not use! Contact your Customer Service.
Excessive vibration of Surface Cleaner OR Cleaner base is creating a suction to the surface.	Nozzle clogged.	Clean or replace.
	Rotating bar, bolts or fittings loose.	Tighten.
	Rotating bar or swivel rotor bent.	Replace.
Streaked cleaning pattern.	Insufficient water supply OR PSI of pressure washer is too low. (Won't allow Rotating Bar to move.)	Increase water supply OR ensure pressure is a minimum of 2000 PSI and GPM is a minimum of 3.0.
	Nozzle clogged.	Clean or replace.
	Cleaning too fast.	Slow down pace.
Water weeping from swivel.	Small amount of seepage is normal.	No modification is necessary.
Water shooting from swivel.	Seal malfunction.	Replace.

# 18 INCH ROTARY SURFACE CLEANER AW-7020-8000

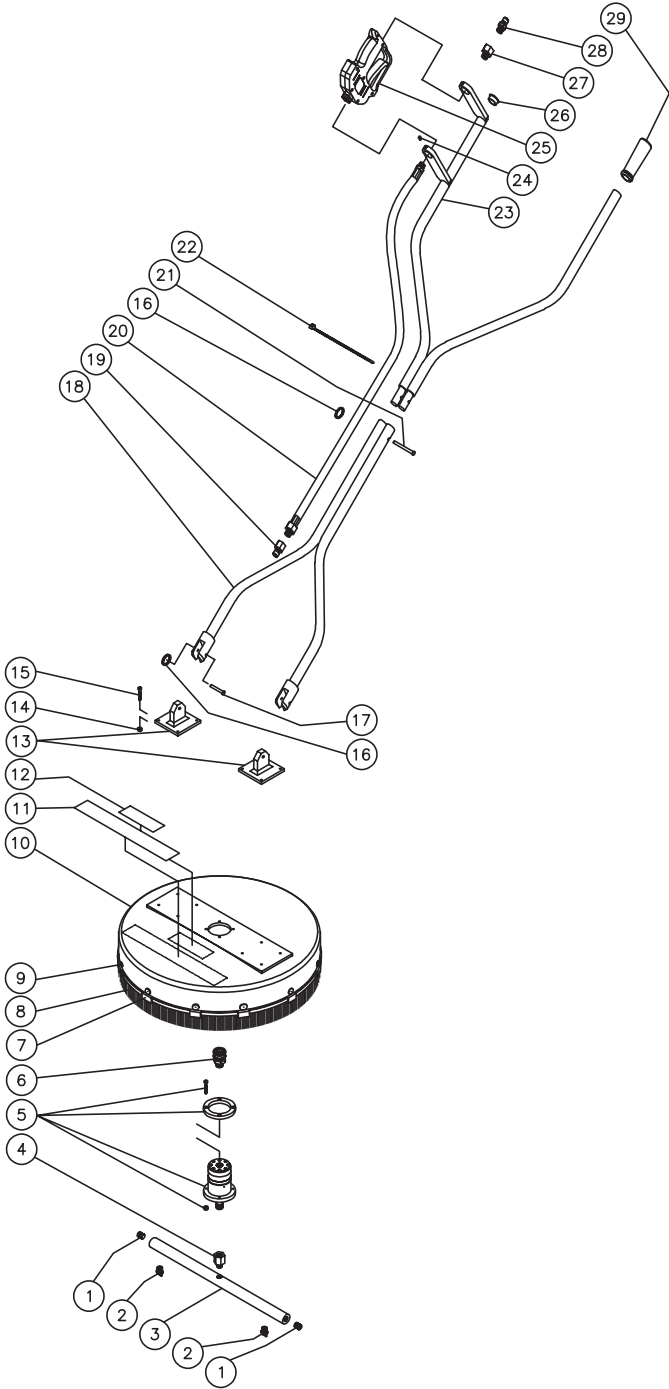

0MGEN269-083017JRC

## 18 INCH ROTARY SURFACE CLEANER

REF. #	DESCRIPTION	PART #	QTY.
1	Screw	27-8911	2
2	Spray Nozzle- 1501.5	18-0294	2
-	Spray Nozzle- 1502	18-0295	2
-	Spray Nozzle- 1502.5	18-0296	2
-	Spray Nozzle- 1503	18-0053	2
-	Spray Nozzle- 2501.5	18-0297	1
-	Spray Nozzle- 2502	18-0298	2
-	Spray Nozzle- 2502.5	18-0299	2
-	Spray Nozzle- 2503	18-0151	2
3	Spray Bar	33-0288	1
4	Steel Reducer	24-0156	1
5	Swivel Assembly	33-0289	1
6	Quick Connect	17-0007	1
7	Clips	33-0477	12
8	Skirt	33-0476	1
9	Rivots	33-0478	12
10	Cover Assembly	33-0290	1
11	Mi-T-M Decal	34-2188	1
12	Decal- Warning	24-0845	1
13	Handle Base	56-0027	2
14	Screw	27-8912	8
15	Nut	30-0136	8
16	Bridge Pin	43-0096	3
17	Clevis Pin	43-0097	2
18	Lower Handle	7-0147	1
19	Quick Connect	17-0006	1
20	High Pressure Hose *(Four Feet Required)	15-0337	1
21	Clevis Pin	43-0098	1
22	Wire Tie	33-0022	7
23	Upper Handle	7-0148	1
24	Screw	27-8913	2
25	Trigger Gun (Before 2007)	16-0351	1
-	Trigger Gun (After 2007)	16-0325	1
26	Cap	62-0108	1
27	Reducer	23-0342	1
28	Quick Connect	17-0005	1
29	Grip	7-0149	1

# SWIVEL ASSEMBLY (33-0289)

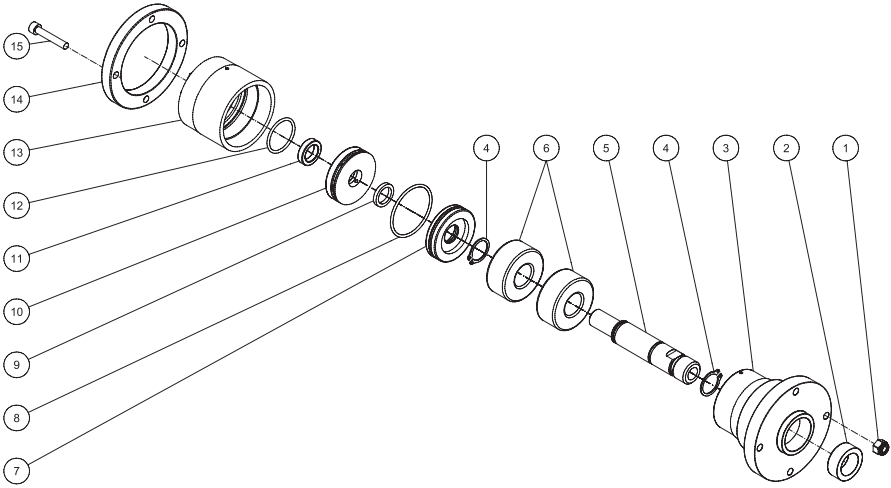



SWIVEL ASSEMBLY			
ITEM	DESCRIPTION	Mi-T-M #	QTY
1	LOCKNUT	30-0136	4
2	QUAD SEAL (SEE KIT 70-0218)	SEE KIT	1
3	BEARING HOUSING	33-0285	1
4	SNAP RING	43-0094	2
5	ROTOR SHAFT	33-0284	1
6	BEARING	48-0068	2
7	LOWER PLATE	33-0283	1
8	STATIC O-RING (SEE KIT 70-0218)	SEE KIT	1
9	SECONDARY SEAL (SEE KIT 70-0218)	SEE KIT	1
10	UPPER PLATE	33-0286	1
11	MAIN SEAL (SEE KIT 70-0218)	SEE KIT	1
12	STATIC O-RING (SEE KIT 70-0218)	SEE KIT	1
13	SEAL CAP	33-0287	1
14	CLAMP RING	43-0095	1
15	BOLT	27-8916	4

REPLACEMENT KIT			
Mi-T-M #	DESCRIPTION	ITEMS	# OF ASSEMBLIES
70-0218	SEAL KIT	2, 8, 9, 11, 12	1

---

## NOTES

---

## STATEMENT OF WARRANTY FOR YOUR ROTARY SURFACE CLEANER

Mi-T-M warrants all parts, (except those referred to below), of your Rotary Surface Cleaner to be free from defects in materials and workmanship during the following periods:

1. For One (1) Year from the date of original purchase:  
High Pressure Swivel
2. For Ninety (90) days from the date of original purchase:  
Rotary Surface System Components

Defective parts not subject to normal wear and tear will be repaired or replaced at our option during the warranty period which upon examination is disclosed to have been defective in material or workmanship. In any event, reimbursement is limited to the purchase price paid.

### Exclusions:

1. Normal wear parts:  
Quick Connects                      Nozzles  
Trigger Gun Valve Assembly
2. This warranty does not cover parts damaged due to normal wear, misapplication, misuse, accidents, operation at other than recommended speeds, pressures or temperature, improper storage or freight damage. Parts damaged or worn because of the use of any type of detergents or by operation in abrasive or corrosive environments are not warranted. Failure to follow recommended operating and maintenance procedures also voids warranty.
3. The use of other than Genuine Mi-T-M Repair Parts will void warranty. Parts returned, prepaid to our factory or to a Mi-T-M Authorized Service Center will be inspected and replaced free of charge if found to be defective and subject to warranty. Under no circumstance shall the manufacturer bear any responsibility for loss of use of the unit, loss of time or rental, inconvenience, commercial loss or consequential damages. There are no warranties which extend beyond the description of the face hereof.

For Service or Warranty Consideration, contact  
Mi-T-M® Corporation  
50 Mi-T-M Drive, Peosta, IA 52068-0050  
563-556-7484 / 800-553-9053 / Fax 563-556-1235  
Monday - Friday 7:30 a.m. - 5:00 p.m. CST

