



OPERATORS MANUAL FOR Mi-T-M®

BIO-20-0M1D

**BIOLOGICAL DISCHARGE
SYSTEM**

⚠ CAUTION

RISK OF INJURY!

READ MANUAL BEFORE OPERATING!

This manual is an important part of the Biological Discharge System and must remain with the unit when you sell it!

Table of Contents

INTRODUCTION.....	3
CONTENTS OF BIOLOGICAL DISCHARGE SYSTEM.....	4
SPECIFICATIONS.....	4
PURPOSE.....	4
IMPORTANT SAFETY WARNINGS.....	5-7
RISK OF ELECTRIC SHOCK OR ELECTROCUTION.....	5
RISK OF EXPLOSION OR FIRE.....	6
RISK OF BURSTING.....	6
RISK OF BURNS.....	6
RISK FROM MOVING PARTS.....	7
RISK OF BODILY INJURY.....	7
FLOW CHART.....	8-9
FEATURES.....	10-11
INSTALLATION.....	12-14
ATTIRE 12.....	
INSTALLATION.....	12-13
PRESTART CHECKLIST.....	14
PREPARATION.....	15
PRESTART PROCEDURES.....	15
START-UP.....	15
OPERATION.....	16
ADDING MICROBES.....	16
MAINTENANCE.....	16-17
ROUTINE MAINTENANCE.....	16
WINTERIZING.....	16-17
TROUBLESHOOTING.....	18-19
REPLACEMENT PARTS.....	20
STATEMENT OF WARRANTY.....	23

WARNING

This product contains one or more chemicals known to the State of California to cause cancer and birth defects or other reproductive harm.

! IMPORTANT !

ALUMINUM TANK AND CHEMICAL USE

The chemicals listed below should not be used in any aluminum tank because of reactions with the alloy. These chemicals may cause premature failure of your tank. Use of any of the listed chemicals will void any warranty expressed or implied by Mi-T-M with regard to your water treatment system.

CHEMICALS TO AVOID:

Aluminum Chloride, Ammonia, Ammonia Hydroxide, Barium Salts, Calcium Chloride, Carbon Tetrachloride, Caustic Soda, Chlorine, Chloroform, Hydrochloric Acid, Hydrogen Peroxide, Methyl Chloride, Oxalic Acid, Ozone, Perchloric Acid, Phosphoric Acid, Potassium Carbonate, Potassium Hydroxide, Sodium Carbonate, Sodium Chloride, Sodium Hydroxide, Sulfuric Acid, Trichloro-acetic Acid, Zinc Chloride.

If you are unsure about a chemical reacting with your aluminum tank, please consult with your Mi-T-M representative.

INTRODUCTION

Congratulations on the purchase of your new Mi-T-M Biological Discharge System! You can be assured your Mi-T-M Biological Discharge System was constructed and designed with quality and performance in mind. Each component has been rigorously tested to ensure the highest level of acceptance.

This operator's manual was compiled for your benefit. By reading and following the simple safety, installation, operation, maintenance and troubleshooting steps described in this manual, you will receive years of trouble free operation from your new Mi-T-M Biological Discharge System. The contents of this manual are based on the latest product information available at the time of publication. Mi-T-M reserves the right to make changes in price, color, materials, equipment, specifications or models at any time without notice.

! IMPORTANT !

These paragraphs are surrounded by a "SAFETY ALERT BOX". This box is used to designate and emphasize Safety Warnings that must be followed when operating this Biological Discharge System.

Accompanying the Safety Warnings are "signal words" which designate the degree or level of hazard seriousness. The "signal words" used in this manual are as follows:

DANGER: Indicates an imminently hazardous situation which, if not avoided, **WILL** result in death or serious injury.

WARNING: Indicates a potentially hazardous situation which, if not avoided, **COULD** result in death or serious injury.

CAUTION: Indicates a potentially hazardous situation which, if not avoided **MAY** result in minor or moderate injury.



The symbols set to the left of this paragraph are "Safety Alert Symbols". These symbols are used to call attention to items or procedures that could be dangerous to you or other persons using this equipment.

ALWAYS PROVIDE A COPY OF THIS MANUAL TO ANYONE USING THIS EQUIPMENT. READ ALL INSTRUCTIONS BEFORE OPERATING THIS BIOLOGICAL DISCHARGE SYSTEM AND ESPECIALLY POINT OUT THE "SAFETY WARNINGS" TO PREVENT THE POSSIBILITY OF PERSONAL INJURY TO THE OPERATOR.

Once the unit has been uncrated, immediately write in the serial number of your unit in the space provided below.

SERIAL NUMBER _____

Inspect for signs of obvious or concealed freight damage. If damage does exist, file a claim with the transportation company immediately. Be sure that all damaged parts are replaced and that the mechanical and electrical problems are corrected prior to operation of the unit. If you require service, contact Mi-T-M Customer Service.

CUSTOMER SERVICE

CALL OUR TOLL-FREE NUMBER

for the Sales or Service Center nearest you!

800-553-9053

Please have the following information available for all service calls:

1. Model Number
2. Serial Number
3. Date and Place of Purchase

CONTENTS OF THE BIOLOGICAL DISCHARGE SYSTEM

Carefully unpack your new Mi-T-M Biological Discharge System. Check the contents against the packing list. Contact the freight line if a damage claim is required on any component. The following items are the basic equipment sent with your Biological Discharge System.

1. Sump pump
2. Blue float for sump pit (protects sump pump low level)
3. Biological Discharge System Platform
 - A. Regenerative blower
4. Water test kit
5. Manual

SPECIFICATIONS

MODEL	BIO-20-0M1D
Maximum Flow	20 GPM
Electrical	230 Volt 1Phase 11Amps
Sump Pump	1/2 HP
Operating Capacity	795 gallons
Biological Media	2304 sq. ft.
Regenerative Blower	1 HP
Dimensions L x W x H (in.)	96 x 48 x 52
Net Weight	749 lbs.

PURPOSE

The Mi-T-M Biological System was designed to offer a solution to waste disposal that is economical, efficient and foremost, *environmentally safe*. As we move into the 21st century, environmental waste codes are becoming more and more strict. Surcharges and fines are being mandated to companies that are unable to operate within acceptable guidelines. Chemicals used to treat waste water often create by-products which in themselves cause additional code violations. Mi-T-M Corporation has solved this problem by engineering a Bio-System that utilizes *microbes*, not chemicals, to literally feed off of the waste in the water allowing the final output to be cleansed of any hazardous by-products. We at Mi-T-M realize the need to protect and respect our environment and therefore, our Bio-Systems operate under specific microbe guidelines, utilizing microbes that (1) is natural, not genetically formulated and (2) will not cause disease.

Mi-T-M has been involved in water products for over twenty-eight years. Our commitment to quality is passed on to our customers, our commitment to the environment is passed on to our children.



IMPORTANT SAFETY WARNINGS



WARNING: When using this product, basic precautions should always be observed, including the following:

READ ALL SAFETY WARNINGS BEFORE USING BIOLOGICAL DISCHARGE SYSTEM





HAZARD	POTENTIAL CONSEQUENCE	PREVENTION
<p>RISK OF ELECTRIC SHOCK OR ELECTROCUTION</p> 	<p>Serious injury or death could occur if the Biological Discharge System is not properly grounded. Your Biological Discharge System is powered by electricity and may cause electric shock or electrocution if not installed properly.</p> <p>Electrical shock may occur if Biological Discharge System is not operated properly.</p> <p>Serious injury or death may occur if electrical repairs are attempted by unqualified persons.</p>	<p>Installation of this unit, including all electrical connections, must comply with all local, state and national codes.</p> <p>This product must be grounded. Connect to a GFCI circuit breaker when available. If the unit should malfunction or breakdown, grounding provides a path of least resistance for electric current to reduce the risk of electric shock. Do not ground to a gas supply line.</p> <p>Improper connection of the equipment-grounding conductor can result in a risk of electrocution. Check with a qualified electrician or service personnel if you are in doubt as to whether the system is properly grounded.</p> <p>Always be certain the unit is receiving proper voltage (+/- 5% of the voltage listed on the nameplate). Before installing electrical connections, be certain the power switches are in the "OFF" position.</p> <p>Keep all connections dry and off the ground.</p> <p>Do not touch pump, pump motor, discharge piping or water when the unit is connected to the power supply; regardless of whether the unit is operating correctly or experiencing an operation failure.</p> <p>DO NOT allow metal components of the Biological Discharge System to come in contact with live electrical components.</p> <p>Never operate the Biological Discharge System with safety guards/covers removed or damaged. Ensure all electrical covers are securely in place when unit is operating.</p> <p>Any electrical wiring or repairs performed on this Biological Discharge System should be done by Authorized Service Personnel in accordance with National and Local electrical codes.</p> <p>Before opening any electrical enclosure, always shut off the Biological Discharge System and drain the water. Disconnect the Biological Discharge System from the power source. If the power disconnect is not in sight, lock it in the open position and tag it to prevent power usage. (Never assume the Biological Discharge System is safe to work on just because it is not operating, it could restart at any time! Always disconnect from the power source.) Allow the Biological Discharge System components to cool down.</p>



IMPORTANT SAFETY WARNINGS

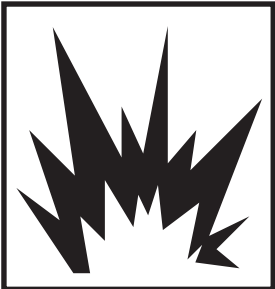

READ ALL SAFETY WARNINGS BEFORE USING BIOLOGICAL DISCHARGE SYSTEM



HAZARD	POTENTIAL CONSEQUENCE	PREVENTION
<p>RISK OF EXPLOSION OR FIRE</p>  	<p>Serious injury or death could occur from an explosion or fire caused by a system electric spark.</p>	<p>This unit must be placed in an area that is well ventilated, free of flammable vapors, combustible dust, gases or other combustible materials.</p>
<p>RISK OF BURSTING</p> 	<p>Serious injury or death could occur from bursting caused by excessive pressure in the system.</p> <p>Serious injury may occur if attempting to start the Biological Discharge System when the pump is frozen.</p>	<p>Do not mistreat the pressure gauges on the system. Pressure gauges will malfunction if they are subjected to excessive pressure, vibration, pulsation or temperature or if they are placed in an environment which causes corrosion of parts. Incorrect readings on a pressure gauge could mislead the operator and place him in a dangerous working condition.</p> <p>Do not use a booster pump or any type of additional pumping system. Pressurizing the suction of the pump may cause the pump body to explode.</p> <p>Do not use this Biological Discharge System to pump flammable material! An explosion could occur from a gas vapor buildup inside the system.</p> <p>In freezing temperatures, the unit must always be warm enough to ensure there is no ice formation in the pump. Do not start the Biological Discharge System if it has been in a freezing environment without first allowing the pump to thaw.</p>
<p>RISK OF BURNS</p> 	<p>Serious injury may occur from touching the electrical motor. This area can remain hot for some time after the Biological Discharge System is shutdown.</p>	<p>Never allow any part of your body to contact the electrical motor until cooled.</p>



IMPORTANT SAFETY WARNINGS



READ ALL SAFETY WARNINGS BEFORE USING BIOLOGICAL DISCHARGE SYSTEM

HAZARD	POTENTIAL CONSEQUENCE	PREVENTION
<p>RISK FROM MOVING PARTS</p> 	<p>Serious injury may occur to the operator from moving parts on the Biological Discharge System.</p>	<p>Do not operate the unit without all protective covers in place.</p> <p>Follow the maintenance instructions specified in the manual.</p>
<p>RISK OF BODILY INJURY</p> 	<p>Injury may occur from the Biological Discharge System.</p>	<p>DO NOT DRINK THE WATER IN THE BIOLOGICAL DISCHARGE SYSTEM!! This is non-potable water and is not suitable for consumption.</p> <p>DO NOT allow children to operate this unit.</p> <p>DO NOT overreach or stand on unstable support.</p> <p>Wet surfaces can be slippery, wear protective foot gear and keep good footing and balance at all times.</p> <p>Know how to stop the Biological Discharge System. Be thoroughly familiar with controls.</p> <p>Before servicing components, ALWAYS shut off the Biological Discharge System.</p> <p>Consult Material Safety Data Sheets (MSDS) for safe handling of system, especially oxidizers and acids.</p>



!SAVE THESE INSTRUCTIONS!



BIOLOGICAL DISCHARGE SYSTEM FLOW CHART

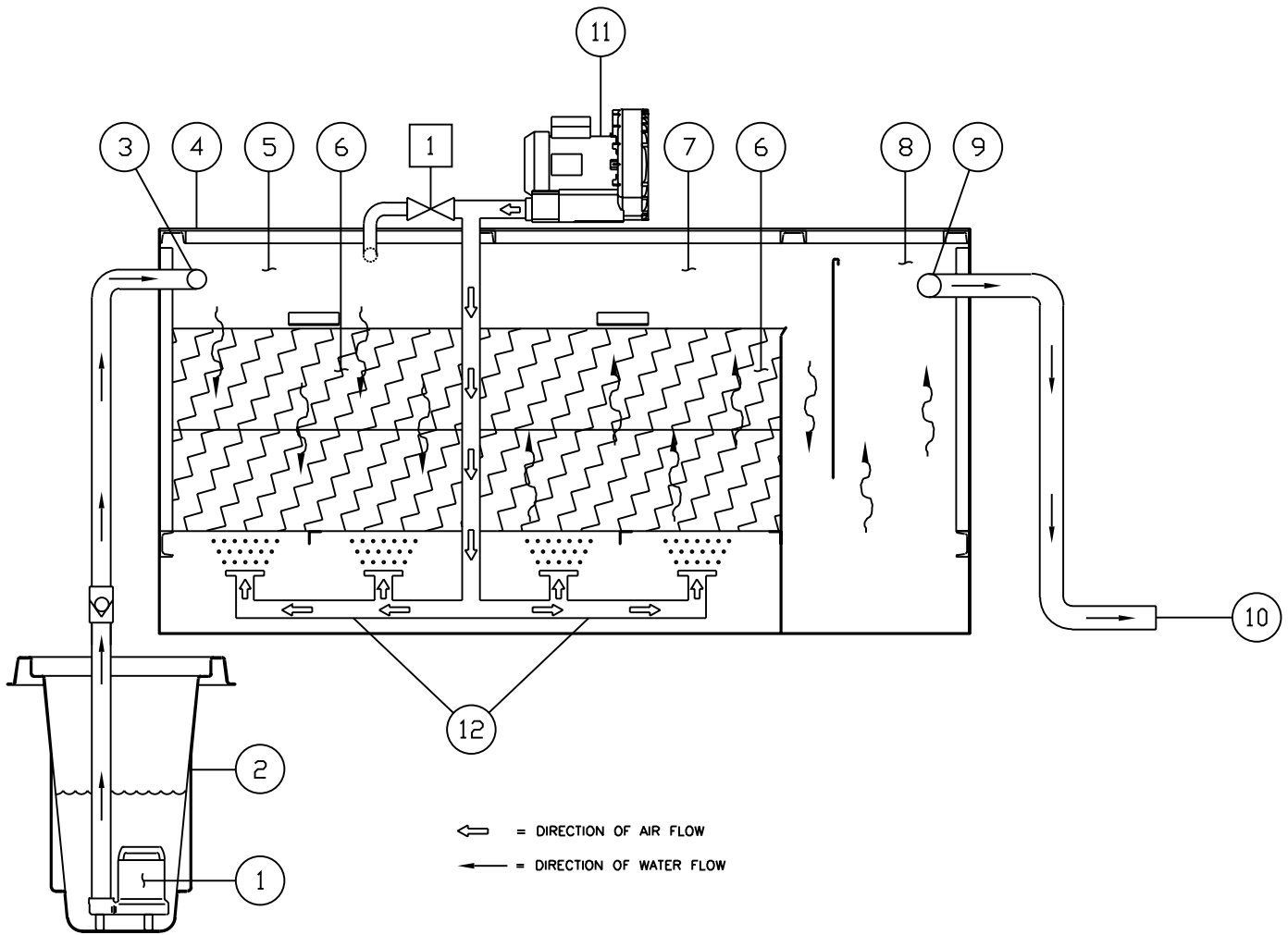

BIO-0027-102899-JJ

BIOLOGICAL DISCHARGE SYSTEM FLOW CHART

The **Sump Pump (1)** draws water from the **Sump Pit (2)** and brings it to the **Inlet (3)** of the Biological Discharge System. **The Biological Discharge Tank (4)** is made up of several sections that are separated by weirs. The wastewater enters the top of the **First Chamber (5)** and moves down through the **Biological Media (6)**. The media packs provide a surface for the microbes to live on. As water passes through the **Biological Media (6)**, the microbes feed off of the organic compounds in the water, producing by-products of carbon dioxide and water. Microbes also need air to live; they receive this by a **Regenerative Blower (11)**, which blows the air into an **Air Diffuser Line (12)**. The air flow is controlled by *Blower Valve 3* to vent some of the air that is pumped by the **Regenerative Blower (11)**, from there the air bubbles up through the **Biological Media (6)**. Without the air in the Biological Discharge System the microbes will not be able to live.

From the **First Chamber (5)**, the wastewater moves under the weir, into the **Second Chamber (7)**, rising up through the **Biological Media (6)** and over the weir. From there the water travels under another weir to the **Holding Tank (8)**. From the **Holding Tank (8)** water flows to the **Holding Tank Outlet (9)**, then flows to the **Outlet to Discharge (10)**.

BIOLOGICAL DISCHARGE SYSTEM FEATURES

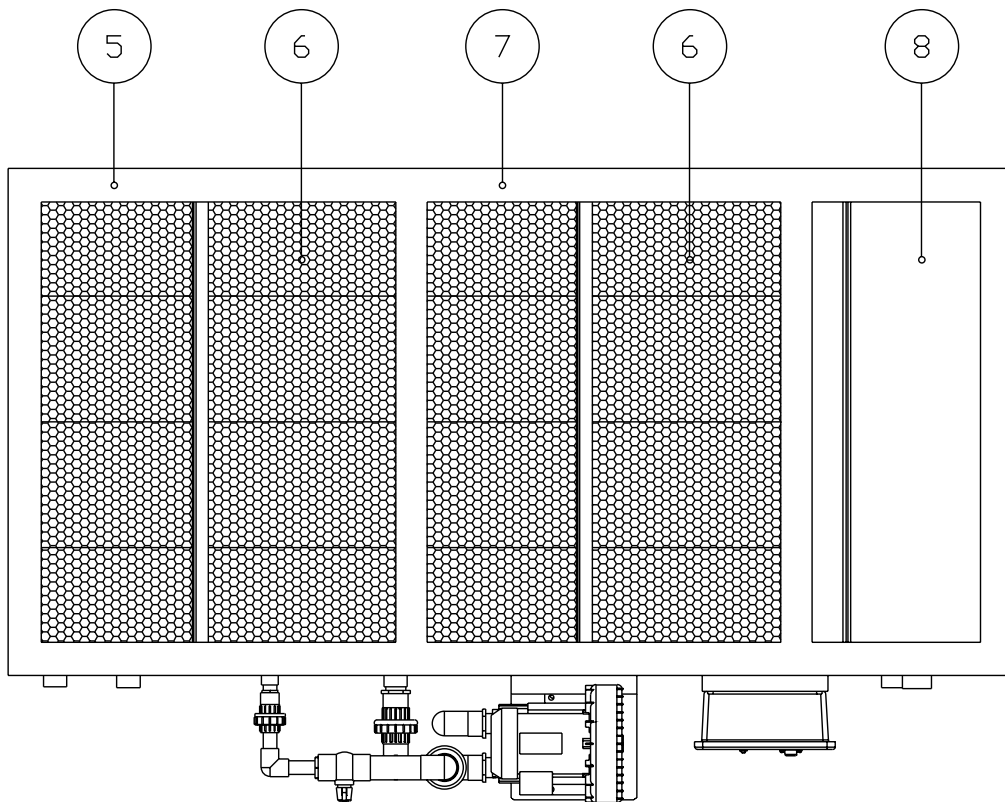

BIO26-102299-JJ

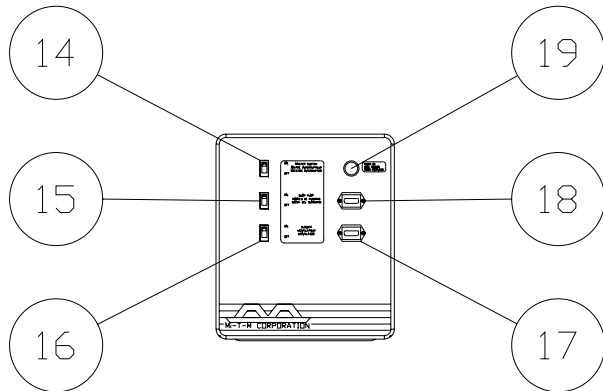

BIO26A-102299-JJ

Blower Valve 1

BIO-DISCHARGE FEATURES

BIO-DISCHARGE FEATURES					
REF. #	DESCRIPTION	REF. #	DESCRIPTION	REF. #	DESCRIPTION
3	Inlet	10	Outlet to Discharge	17	Hour Meter: Blower
4	Biological Tank	11	Blower	18	Hour Meter: Sump Pump
5	First Chamber	12	Air Diffuser Line	19	Power Indicator Light
6	Biological Media	13	Control Panel	20	Drain Ports
7	Second Chamber	14	Master Switch	21	Side Fork Lift Holes
8	Holding Tank	15	Switch: Sump Pump	22	End Fork Lift Holes (6' or greater fork required.)
9	Holding Tank Outlet	16	Switch: Blower		

BIOLOGICAL DISCHARGE SYSTEM FEATURES

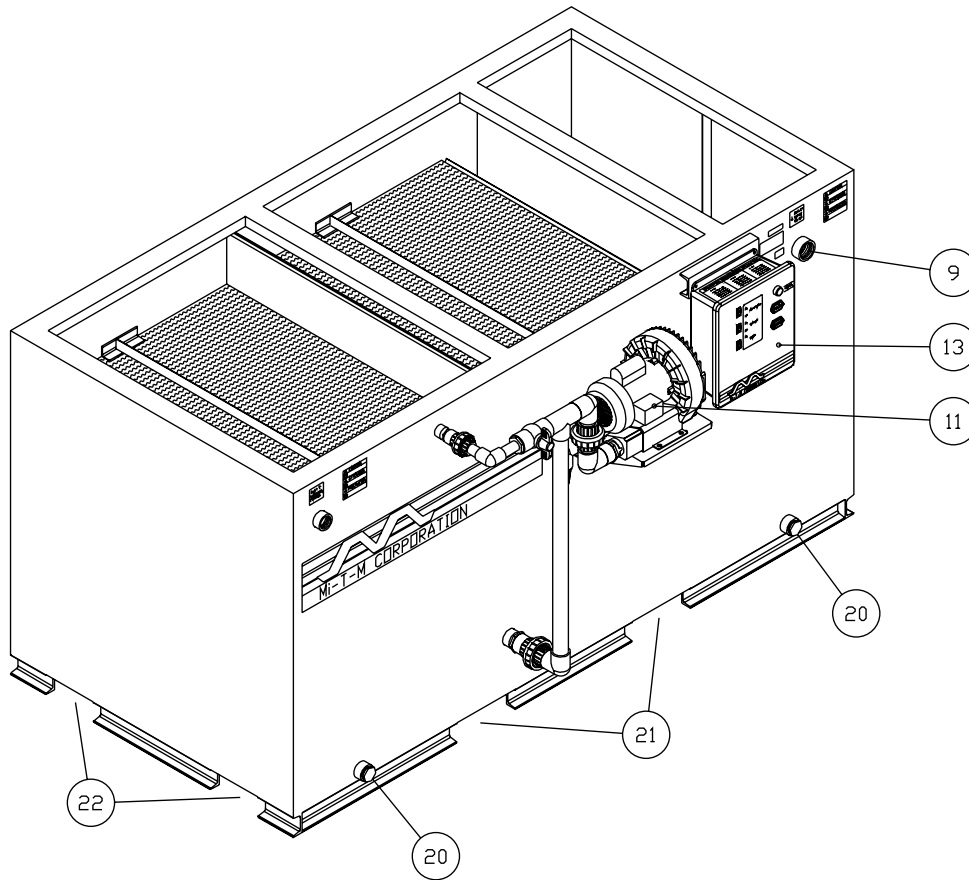

BIO26C-102299-JJ

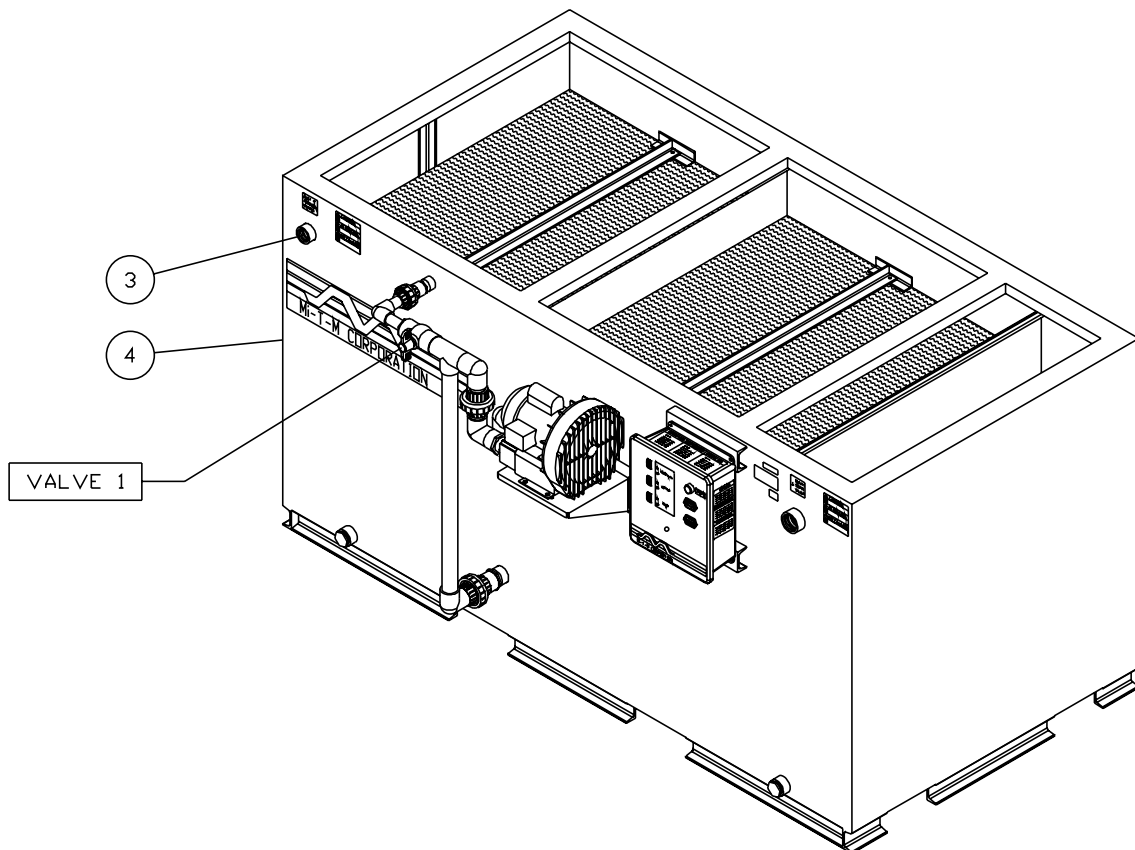

BIO26B-102299-JJ

INSTALLATION

ATTIRE:

1. Proper attire is essential to your safety. It is advised to utilize whatever means necessary to protect eyes, ears, and skin.

INSTALLATION:

1. A Collection Pit System must already be an established structure before installing the Biological Discharge System. A well designed pit system is critical for the proper operation of the discharge system. Consult your Mi-T-M dealer for installation requirements.
2. Place the Biological Discharge System platform on a hard, level surface in an area free of flammable vapors, combustible dust, gases or other combustible materials.
3. Set the unit so you have access to the filters, **Control Panel (13)** and **Drain Ports (20)**.
4. Do not place unit in an area:
 - a. with insufficient ventilation.
 - b. where environmental hazards (i.e. rain and snow) can come in contact with the Biological Discharge System.
 - c. in a freezing environment.
5. Check all union connections for tightness.
6. Install schedule 80 PVC connections to the water inlet of the Biological Discharge System.
7. Install the **Sump Pump** in the **Sump Pit** as shown below.
8. Install plumbing from the **Sump Pump** using 1 1/2" minimum connection sizes.
9. Install the float in the **Sump Pit**. Allow a 2" tether and enough room for them to move freely without interfering with the plumbing.
 - a. Float-Blue: Pit low level shut-off. Attach this float 10" above the **Sump Pump** inlet.

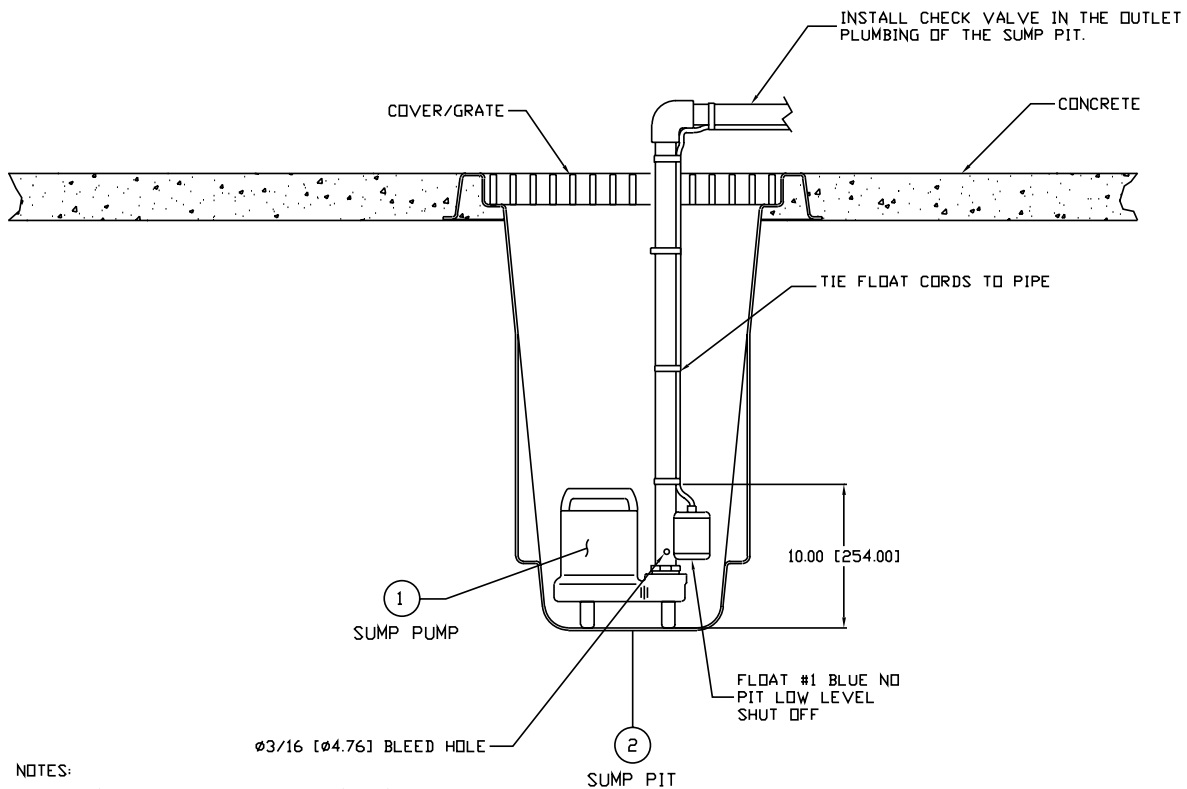

BIO23-102299

INSTALLATION

WARNING

RISK OF ELECTROCUTION! TO REDUCE THE RISK OF ELECTROCUTION, KEEP ALL CONNECTIONS DRY AND OFF THE GROUND.

10. A qualified electrician must hook up the electrical system.
 - a. Verify the electrical supply at the power source is off.
 - b. Be certain all switches on the **Control Panel (13)** are in the "OFF" position.
 - c. Run water tight conduit
 1. From the **Sump Pump (1)** and Float to the **Control Panel (13)**.
 2. From the local disconnect to the **Control Panel (13)**. The electrician will need to drill holes in the **Control Panel** for the conduit.
 - d. Make connections to the terminal strips as shown in the wiring diagram on the following page.
11. Install plumbing using 2" minimum connections from **Holding Tank Outlet (9)** to a sanitary sewer or storage tank for further processing or disposal. Do not send the water back to the **Sump Pit (2)**.

NOTE: In most cases, you must have a permit to legally dispose discharged water.

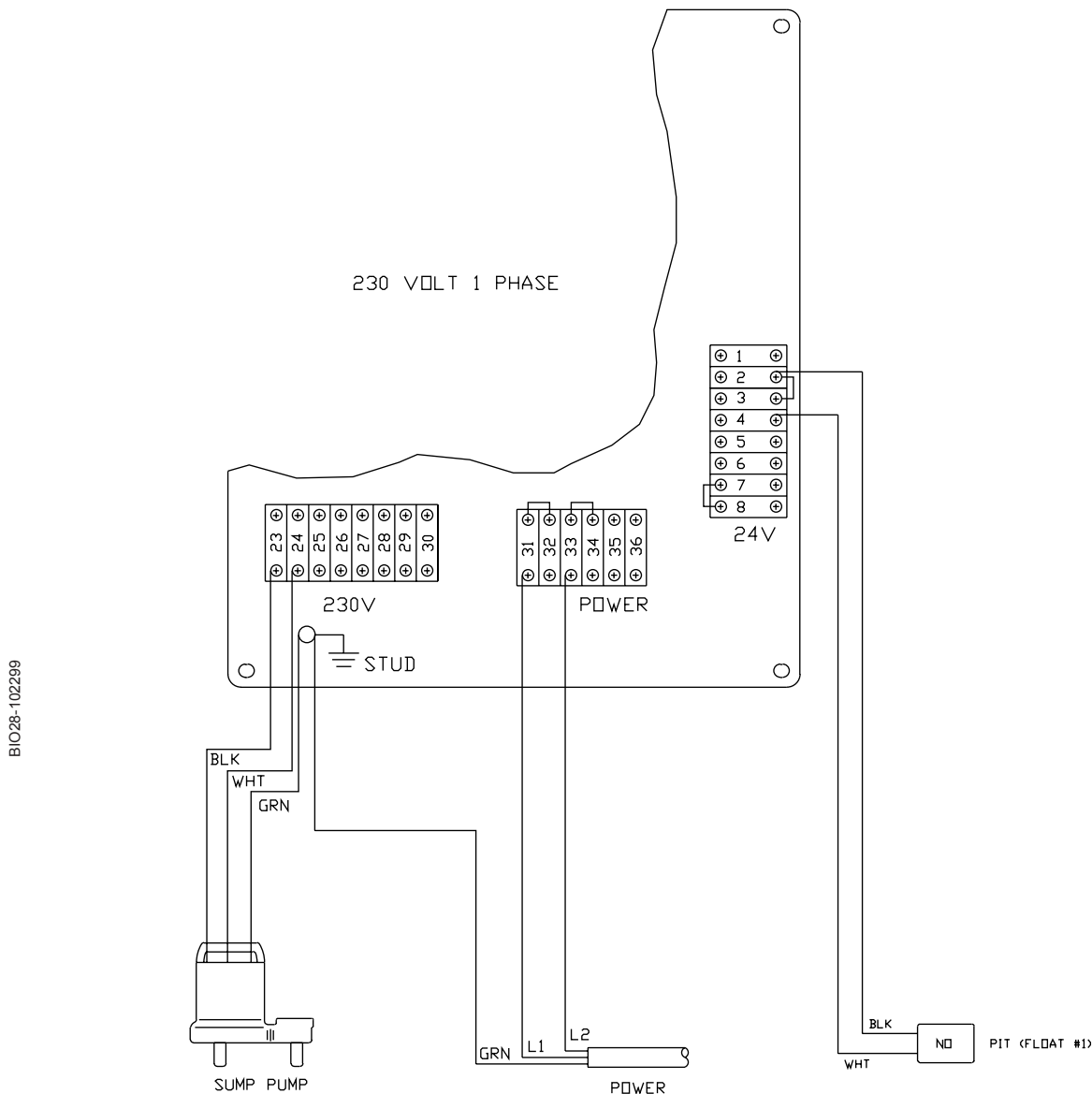

STOP

TO ENSURE YOUR WATER DISCHARGE TREATMENT SYSTEM OPERATES SAFELY AND EFFICIENTLY, COMPLETE THE PRE-OPERATION CHECKLIST BEFORE PROCEEDING.

PRE-OPERATION CHECKLIST

Before proceeding, answer all the questions on this checklist.	YES	NO
CODES:		
1. Does the electrical wiring meet all codes?		
2. Does plumbing meet all codes?		
LOCATION:		
1. Is the unit located on a hard level surface free of flammable vapors, combustible dust, gases or other combustible materials?		
2. Is the unit located in a large ventilated area?		
ELECTRICAL:		
1. Is the unit properly grounded?		
2. Does the power supply, voltage and amperage match the data plate?		
PLUMBING:		
1. Is the plumbing sized correctly?		
2. Are all plumbing connections secure?		
GENERAL:		
1. Have all operators using this unit read and understood this entire manual?		
2. Has the unit been installed by qualified service people who followed the instructions listed in this manual?		

IF "NO" WAS MARKED TO ANY OF THESE QUESTIONS, CORRECT THE SITUATION BEFORE OPERATING.

PREPARATION

PRESTART PROCEDURES:

1. Position the valve on the Biological Discharge System in the “Start-up Mode”.
– *Blower Valve 1*: Turn to the open position.
2. Be certain all plumbing/hoses are tight and properly connected.
3. Be certain the incoming air pipe to the **Blower (11)** is not obstructed.
4. Be certain all switches on the **Control Panel (13)** are in the “OFF” position.

START-UP:

1. Ensure all **Hold Down Angles (23)** are fastened into Biological Tank
2. Fill **Biological Discharge Tank (4)** with water.
3. Turn power from main disconnect “ON”, “POWER ON” **Indicator Light (19)** should be lit.
4. Turn on the **Master Switch (14)**.
5. Turn on the **Blower Switch (16)**, adjust Blower Valve 1 until the surface air bubbles are similar to a rolling boil. Air should be releasing from four diffusers in each chamber. Bubbles should appear at the surface corresponding to each diffuser. If a visual check indicates one of the diffusers is not working, review Troubleshooting. Do not proceed until all diffusers are working.
6. Turn the **Sump Pump Switch (15)**
7. Operate the Biological Discharge System for one hour before adding Mi-T-M microbes.

OPERATION

ADDING MICROBES:

1. Open and pour four 500mL containers of the Mi-T-M prepackaged microbes into the first chamber of the Biological System.
2. Begin your normal cleaning operation.
3. Continue inoculations on a weekly basis to ensure the Bio-System is operating at optimum efficiency.
4. Monitor the system closely the first few days to ensure smooth operation. See Troubleshooting if problems occur.

The Mi-T-M microbes are most active and effective when the water temperature is between 70°F and 100°F. For climates where freezing temperatures are experienced, the Biological System should be enclosed in a heated room.

MAINTENANCE

ROUTINE MAINTENANCE:

1. Pits should be kept free from large amounts of sludge.
2. For most applications, four 500 mL bottles of Mi-T-M microbes should be added to the system each 30 days to ensure a healthy colony growth in the Biological System. The media pack should feel "slimy" to the touch when the microbe colony is established. (Some applications may require more or less microbes depending on the contaminant level.)
3. The pH of the water should not be lower than 5.5 or higher than 8.5 at any given time.
4. If soap is necessary for washing, the soap should be of a neutral pH (approximately 7).

WINTERIZING:

1. Turn all switches on the **Control Panel (13)** to the off position and disconnect power to the **Control Panel (13)**.
2. Shut off all water connections to the Biological Discharge System
3. Open the check valve near the **Sump Pit (2)** and drain the water transport line. Remove the **Sump Pump (1)** from the **Sump Pit (2)**
4. Remove the drain plugs from the **Biological Tank (4)**, clean the tank, **Biological Media (6)** and wipe down the system
5. Loosen all unions in the **Air Diffuser Line (12)**, and all unions, on the exterior of the **Biological Tank (4)**
6. Loosen the plumbing on the **Tank Inlet (3)** and the **Holding Tank Outlet (9)**.
7. Store all chemicals at room temperature.

TO OPERATE UNIT AFTER WINTERIZING:

1. Follow **Installation Instructions** on page 12.
2. Retighten union connection in **Air Diffuser Line (12)** shown on page 12.
3. For ease of reinstalling **Biological Media (6)**, place media at an angle as shown on page 17. After media is replaced, the **Hold Down Angles (23)** must be fastened into the **Biological Tank (4)** before filling. This prevents the **Biological Media (6)** from rising out of the tank and also supports the tank sides.
4. Follow **Prestart Procedures** on page 15.
5. Follow **Start-up Procedures** on page 15.
6. Follow procedures for **Adding Microbes** as described above.

MAINTENANCE

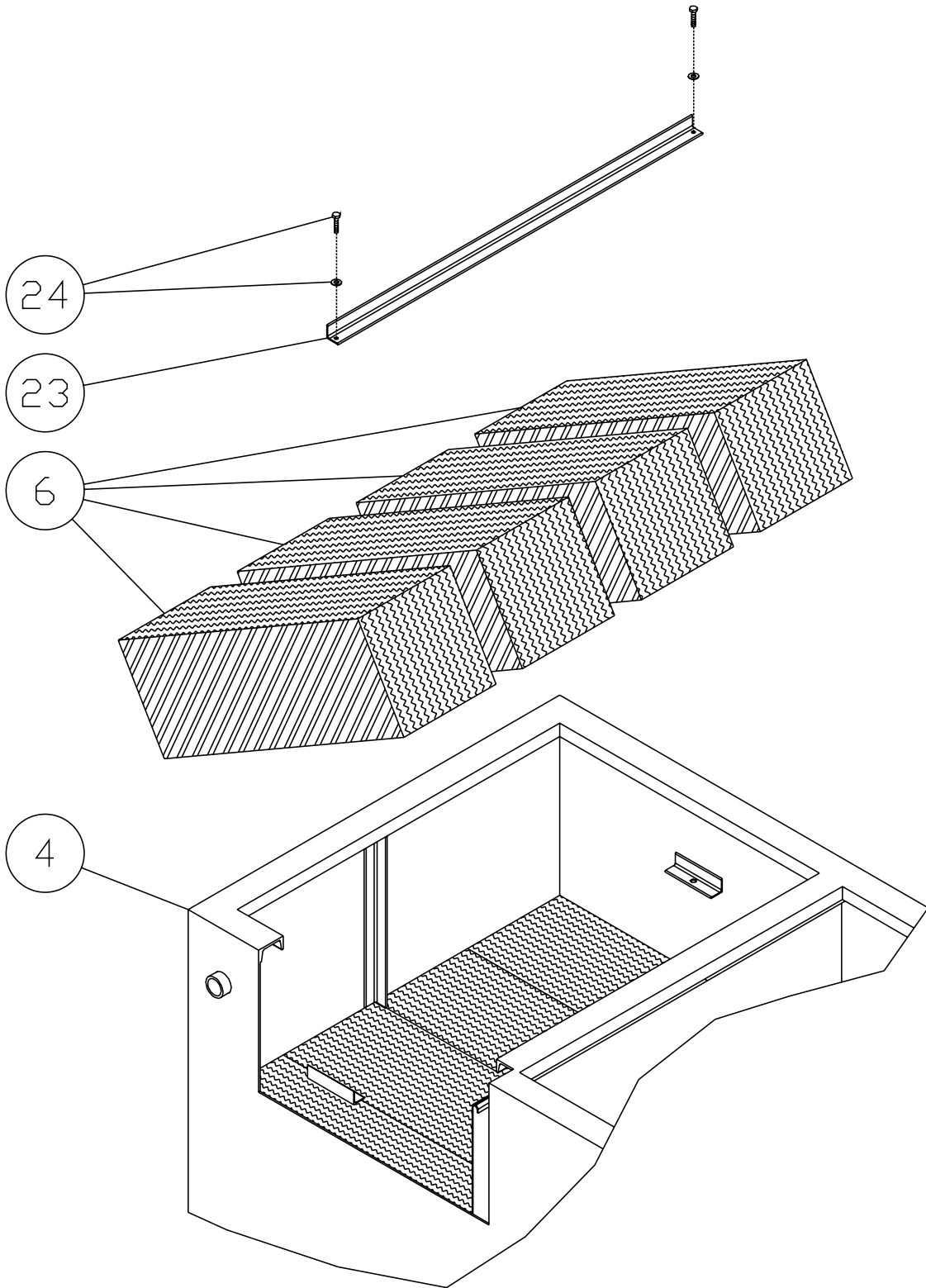

BIO30-102299

TROUBLESHOOTING

SYMPTOM	PROBABLE CAUSE	REMEDY
ELECTRICAL		
No power at Control Panel (13) .	Power failure to Control Panel (13) .	Check circuit breaker at power source or contact your local distributor.
Power Indicator Light (19) is OFF.	Blown fuses inside Control Panel (13) on step down transformer.	Check fuses, replace if necessary. If fuses are OK, contact your distributor.
SUMP PUMP		
Sump Pump will not run.	Float is not adjusted correctly in the Sump Pit .	Readjust.
	Float 1 is defective.	Replace.
	Circuit overload/breaker has tripped.	Reset breaker or replace fuse at power source.
	Motor overload.	Allow motor to cool. Motor will automatically restart when cool.
Sump Pump motor starts and stops frequently during operation.	Motor is defective. This is a common occurrence.	Replace motor. Allow pits to fill.
	Sump Pump impeller is clogged.	Disconnect power and unclog impeller.
	Motor overload.	Allow motor to cool. Motor will automatically restart when cool.
Sump Pump runs, but there is little or no water discharge.	Sump Pit is not large enough. Water level is below pump inlet.	Expand size of pit. Ensure Float 1 is not caught in plumbing.
	There is an air lock in the Sump Pump .	Manually fill the inlet pipe with water. Turn the Sump Pump on and off several times.
	Low voltage.	Ensure wire size is capable of handling the rated amperage of the unit. If wire size is correct, contact your distributor.
	Sump Pump impeller is clogged.	Disconnect power and unclog impeller.
Sump Pump will not turn off.	Worn pump parts. Defective switch inside Float 1.	Contact your distributor. Replace.
	Pump is air locked.	Cycle pump in one minute increments several times to clear air from pump. If system includes a check valve, a 3/16" hole should be drilled in the discharge pipe approximately 2" above the discharge connections.

TROUBLESHOOTING

SYMPTOM	PROBABLE CAUSE	REMEDY
BIO-SYSTEM TANK		
Water will not flow into the Bio-System Tank .	Sump Pump is not turned on.	Move Sump Pump Switch to "ON"
	Circuit breaker has tripped or is "OFF".	Reset or turn breaker "ON".
	Dirt is lodged in the inlet check valve.	Clean.
	Sump Pump impeller is clogged.	Disconnect power and clean.
	Lines or valves contain frozen water.	Allow to thaw. Inject with warm water if necessary.
SHAFT SEALS		
Short seal life.	Unexpected temperature and chemical usage.	Replace.
Water is leaking at pump.	Damaged stationary shaft seal.	Seal ran dry. Ensure seal chamber is filled with liquid.
ODOR		
Excessive odor in water system.	Not enough microbes in the system to maintain water balance.	Increase the microbe inoculation.
	Too much waste water for microbes to digest.	Use of chemical injection or use of an additional Bio-System may be necessary.
	*****Water remains dormant in the system too long causing bacteria buildup.	The Biological System and Blower should be on 24 hours per day.
BLOWER		
Blower will not run.	Blower Switch (16) is off.	Turn Blower Switch (16) on.
	Circuit overload. Breaker has tripped.	Reset breaker or replace fuse.
	Motor overload.	Allow motor to cool. Motor will automatically restart when cool.
Blower runs but little or no air to outlet.	Plumbing unions not tight.	Tighten unions.
	Inlet filter blocked or obstructed.	Remove foreign object.
	Blower filters dirty or clogged.	Contact your local distributor.
	Blower motor is operating below maximum RPM.	Contact your local distributor.
Blower is hot or turns off.	Low voltage.	Ensure wire size is capable of handling the rated amperage or the unit . If wire size is correct, contact your local distributor.
	Motor overload.	Allow motor to cool. Motor will automatically restart when cool.

REPLACEMENT PARTS

DESCRIPTION	REORDER #
Microbes-Oil, Grease and HC's; Four 500mL.....	RC-2001-0001
Microbes-Oil, Grease and HC's; Four 500mL.....	RC-2002-0001
Microbes-Oil, Grease and HC's; Four 500mL.....	RC-2003-0001
Test Strips.....	33-0314

NOTES

NOTES

STATEMENT OF WARRANTY

Mi-T-M warrants all parts (except those referred to below) of your new Biological Discharge System to be free from defects in materials and workmanship during the following periods:

For One (1) Year from the date of original purchase:

Defective parts not subject to normal wear and tear will be repaired or replaced at Mi-T-M's option during the warranty period. In any event, reimbursement is limited to the purchase price paid.

EXCLUSIONS

1. The motor is covered under separate warranty by its respective manufacturer and is subject to the terms set forth therein.
2. Normal wear parts:

Seals	Filters	Gaskets
O-rings	Packings	Pistons
Valve Assembly	Brushes	Microbes
Sensors		
3. Parts damaged due to:
 - normal wear, misapplication, modifications/alterations, abuse,
 - operation at other than recommended speeds, pressures or temperature,
 - the use of caustic liquids,
 - chloride corrosion or chemical deterioration,
 - fluctuations in electrical or water supply,
 - operating unit in an abrasive, corrosive or freezing environment.
4. Parts damaged by failure to follow recommended:
 - installation, operating and maintenance procedures.
5. This warranty does not cover the cost of:
 - normal maintenance or adjustments,
 - labor charges,
 - transportation charges to Service Center,
 - freight damage.
6. The use of other than genuine Mi-T-M parts will void warranty. Parts returned, prepaid to Mi-T-M's factory or to an Authorized Service Center will be inspected and replaced free of charge if found to be defective and subject to warranty. There are no warranties which extend beyond the description of the face hereof. Under no circumstances | shall Mi-T-M bear any responsibility for loss of use of the unit, loss of time or rental, inconvenience, commercial loss or consequential damages.

