

HSP Series | Gasoline Direct Drive

The HSP Series features a patented Electro Magnetic Firing (EMF) system which eliminates the need for a 12V battery to operate the burner. The top-fired heat exchanger is designed for easy maintenance.



HSP-2503-0MMH

Pump

- Direct drive triplex piston AR or Mi-T-M pump with ceramic plungers
- Stainless-steel and brass unloader valve, preset
- Forged brass mainfold
- Thermal relief valve
- Low pressure detergent injector (Available as an option on HSP-250-0MMH)

Engine

- Performance proven engine with low-oil protection

Frame

- Reinforced powder coated steel tube frame with center balanced lifting hook
- Flat-free tires

Components

- Top-fired powder coated heat exchanger
- No. 1 or No. 2 diesel or kerosene fired burner (Not approved for bio-fuel)

Miscellaneous

- Temperature rise 150°F/66°C above ambient, maximum outlet temperature is 200°F

Unit Includes:

- Quick connect nozzles – 0°, 15°, 25° and 40°
- 50-foot x 3/8-inch steel wire-braided high pressure hose with quick connects, swivel and bend restrictors
- Adjustable pressure insulated dual lance
- Insulated trigger gun with safety lock-off



HSP-3504-3MGH



HSP Series | Gasoline Direct Drive



Model Number	PSI	GPM	Displacement/Engine	Pump	Engine Fuel Tank Capacity	Burner Fuel Tank Capacity	Burner Fuel Consumption	BTU per hour	Dimensions (LxWxH)	Ship Wt.	Net Wt.
HSP-2503-0MMH	2500	2.6	196cc Honda GX200 OHV	Mi-T-M	0.95 gallon	4.0 gallons	1.53 gph	210,000	43x29.5x36.5in.	411 lb.	295 lb.
HSP-3003-3MGH	3000	2.9	270cc Honda GX270 OHV	AR, external bypass	1.59 gallons	5.5 gallons	1.84 gph	253,000	43x30x41in.	530 lb.	407 lb.
HSP-3504-3MGH	3500	3.3	389cc Honda GX390 OHV	AR, external bypass	1.70 gallons	5.5 gallons	2.14 gph	294,000	43x30x41in.	551 lb.	428 lb.
HSP-3504-3MGK	3500	3.3	429cc Kohler CH440 OHV	AR, external bypass	1.70 gallons	5.5 gallons	2.14 gph	294,000	43x30x41in.	551 lb.	428 lb.

Options:		
Part Number	Description	Fits Models
HX-0098	Electric start (Battery included) - For easy starting	HSP-3504-3MGH
HX-0233	Adjustable thermostat - Operator is able to adjust outlet water temperature between 98°-248°F	HSP-2503-0MMH
HX-0234	Low pressure detergent injector - Allows the user to apply the recommended detergents	HSP-2503-0MMH
HX-0236	Hour meter - Displays the number of hours unit has been in operation	HSP-2503-0MMH
HX-0250	Adjustable thermostat - Operator is able to adjust outlet water temperature between 98°-248°F	3000 to 3500-PSI models

Accessories:		
Part Number	Description	Fits Models
20-0464A52	Rain cap - Protects boiler from moisture build-up when unit is left outside	3000 & 3500-PSI models
50-0161	High pressure detergent injector - High pressure water mixes with detergent to clean even the heaviest build-up	All models
850-0433	50-ft. x 3/8-inch high pressure hose - For when you need extra hose for added mobility	3500-PSI models
851-0262	50-ft. x 3/8-inch high pressure hose - For when you need extra hose for added mobility	2500 to 3000-PSI models

POWERED by **HONDA**™

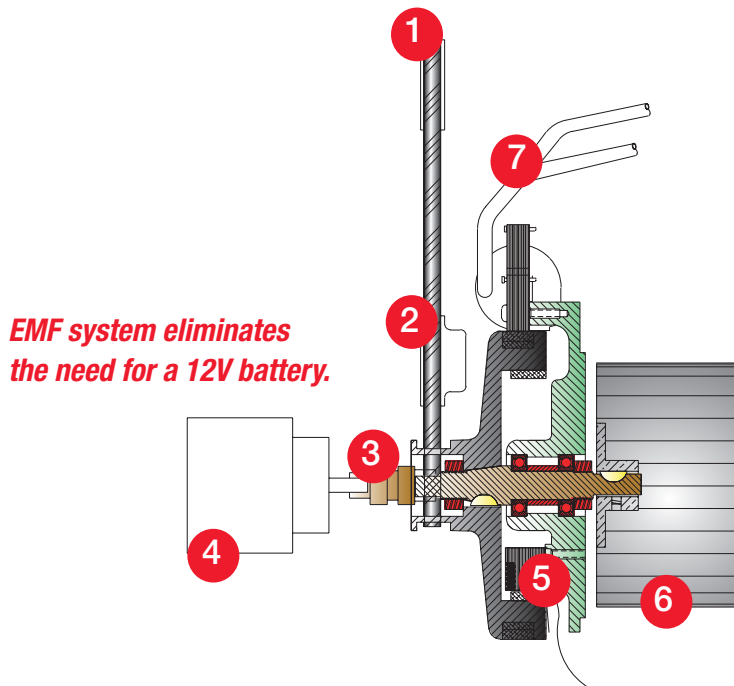

Patented Electro Magnetic Firing (EMF) System

1. Engine sheave, dual set screw mount, maintains proper alignment of pump shaft key.
2. The belt tension sheave creates proper belt tension so fuel pump discharges fuel upon demand.
3. The long lasting, non-corrosive flexible drive coupler protects the EMF system if fuel pump locks up.
4. Fuel pump is a durable high quality pump that will deliver No. 1 or No. 2 diesel fuel or kerosene.
5. Stator coil/magnets are a low maintenance system that provides solenoid control voltage.
6. Fan provides burner air for proper combustion and clean exhaust smoke. It has an easily accessible air flow control.
7. Ignition coil provides voltage to electrodes for proper spark voltage, allowing accurate ignition of fuel every time the trigger is pulled. The ignition coil has a long life, is easily replaced and has a proven track record in the industry.