



WOS & WCL Series



Mi-T-M Water Treatment Systems provide a better tomorrow by protecting our environment today.

The WOS and WCL water treatment systems are able to treat wastewater to meet your local sanitary sewer discharge requirements. These systems separate oil, water and solids in wastewater for proper disposal and remove free oils from wash water and clarifies it for reuse.

WOS Series

Above-Ground Oil/Water/Solids Separators

Mi-T-M designed the mechanical oil/water separator to remove free oils before discharging to your sanitary sewer. The oil/water/solids separators will reduce the amount of suspended solids while removing hydrocarbons to meet stringent local sanitary sewer discharge requirements.

Mi-T-M's WOS Series Consists Of Above-Ground Oil/Water/Solids Separators Designed To Discharge Equipment and Vehicle Wash Water Into Sanitary Sewers.

The WOS Series Offers The Following Features:

- Ozone
- Stainless-steel tank
- Capability of handling oil and solids conveniently
- Takes up an extremely small footprint
- Easy to maintain
- CSA approved control panel which meets the requirements of the US and Canadian standards for an Industrial Control Panel
- 1.0 HP surface-mount sump pump



CSA listed NEMA-4 rated corrosion-proof control panel for safe and reliable operation

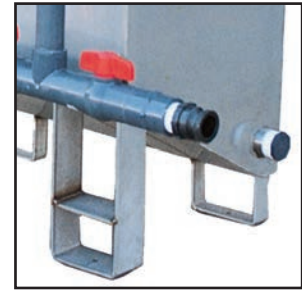

Sloped bottom design for easier solids removal



WOS-15-0M10 shown with continuous recirculation option, WX-0001

MODEL NUMBER	FLOW RATE	COALESCING MEDIA	TANK HOLDING CAPACITY	IN-LINE STRAINER PUMP	POWER REQUIREMENTS	DIMENSIONS (LxWxH)	SHIP WT.
WOS-15-0M10	0-15 GPM	672 sq. ft.	170 gallons	1.0 HP, 120V	120V, 1Ø, 15.0A	91x31x40in.	675 lb.
WOS-15-0M30	0-15 GPM	672 sq. ft.	170 gallons	1.0 HP, 230V	208-230V, 3Ø, 5.0A	91x31x40in.	675 lb.
WOS-30-0M10	0-30 GPM	1,152 sq. ft.	340 gallons	1.0 HP, 120V	120V, 1Ø, 15.0A	97x50x44in.	865 lb.
WOS-30-0M30	0-30 GPM	1,152 sq. ft.	340 gallons	1.0 HP, 230V	208-230V, 3Ø, 5.0A	97x50x44in.	865 lb.

Accessories:

PART NUMBER	DESCRIPTION	FITS MODELS
855-0002	Replacement media - Initial chamber	WOS-15 models
855-0008	Replacement media - Main chamber	WOS-30 models
855-0009	Replacement media - Initial chamber	WOS-30 models
855-0010	Replacement media - Main chamber	WOS-15 models

Options:

PART NUMBER	DESCRIPTION	FITS MODELS
WX-0001	Continuous recirculation - Recirculates back to the pit to prevent water from becoming stagnant	All models
WX-0057	230V, 1Ø - Upgrades 120V model to operate at 230V	WOS-15-0M10
WX-0058	460V, 3Ø - Upgrades 208-230V model to operate at 460V	WOS-15-0M30
WX-0059	230V, 1Ø - Upgrades 120V model to operate at 230V	WOS-30-0M10
WX-0060	460V, 3Ø - Upgrades 208-230V model to operate at 460V	WOS-30-0M30

Process & Flow Description

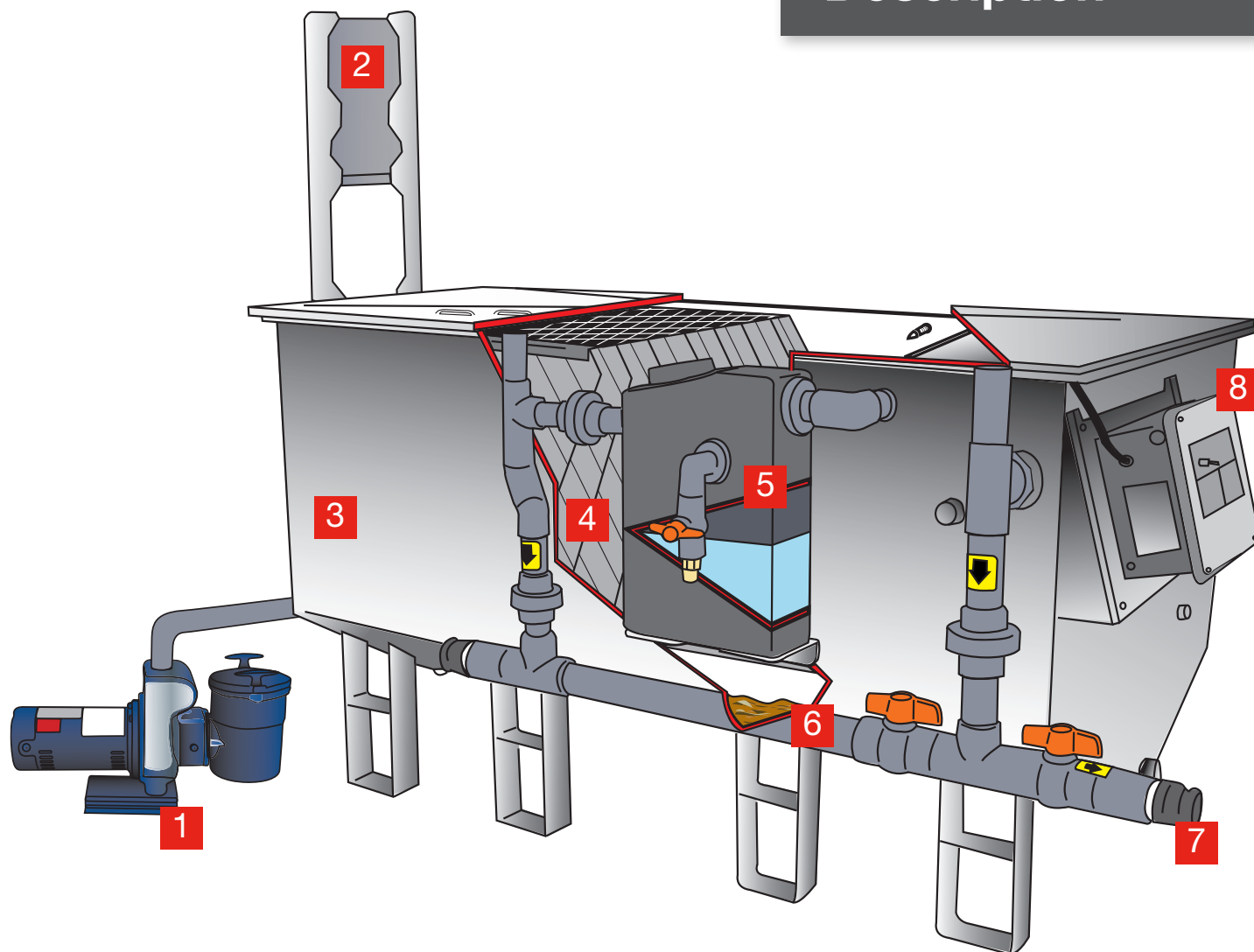

- 1. Surface-Mount Sump Pump** - Untreated wash water is introduced into the system via a 1.0 HP surface-mount sump pump, which is included with the system.
- 2. Corona Discharge Ozone System** - As the wash water is pumped into the oil/water/solids separator and it is injected with a high concentration of ozone via a corona discharge ozone injector system for a "quick kill" of live bacteria on contact. Ozone also breaks up emulsified oils, allowing them to coalesce and float to the top of the tank for separation into the oil decanter.
- 3. Three-Stage Stainless-Steel Tank** - As the water flows through the stainless-steel three-stage oil/water/solids separator, it changes the overall flow direction several times as it flows around four vertical baffles. The water is slowed down and fine silt and solids drop to the bottom of the tank.
- 4. Bio-Film Generative Media** - As the water progresses through hundreds of square-feet of honey-combed-shaped meshed oleophilic (oil attracting) coalescing media, it will change directions countless times. In this process, mechanically emulsified oil particles are attracted from the water to the oleophilic media and float to the surface.
- 5. Oil Skimmer/Decanter** - Once the oil floats to the water's surface, it is then skimmed into an oil decanter for easy disposal.
- 6. Sloped Solids Trap** - Fine silt and particles are dropped to the bottom of the sloped stainless-steel tank for easy flushing and disposal of the accumulated solids.
- 7. Discharge Port** - Once the water has been treated, it flows into the final chamber of the stainless-steel tank and is gravity-fed through a 2-inch drain line to the sanitary sewer drain in the floor.
- 8. Electrical Control Panel** - CSA listed NEMA-4 rated corrosion-proof control panel for safe and reliable operation.

Sample Equipment Wash Pad Application

Remote Box for Pressure Washer with Hose Reel and Wall Mount Bracket (#50-0196 and #13-0207A01)

HEG-3004-0E2G (Electric Powered Natural Gas Fired Hot Water Pressure Washer)

Model #WOS-30-0M10 Above-Ground Oil/Water/Solids Separator

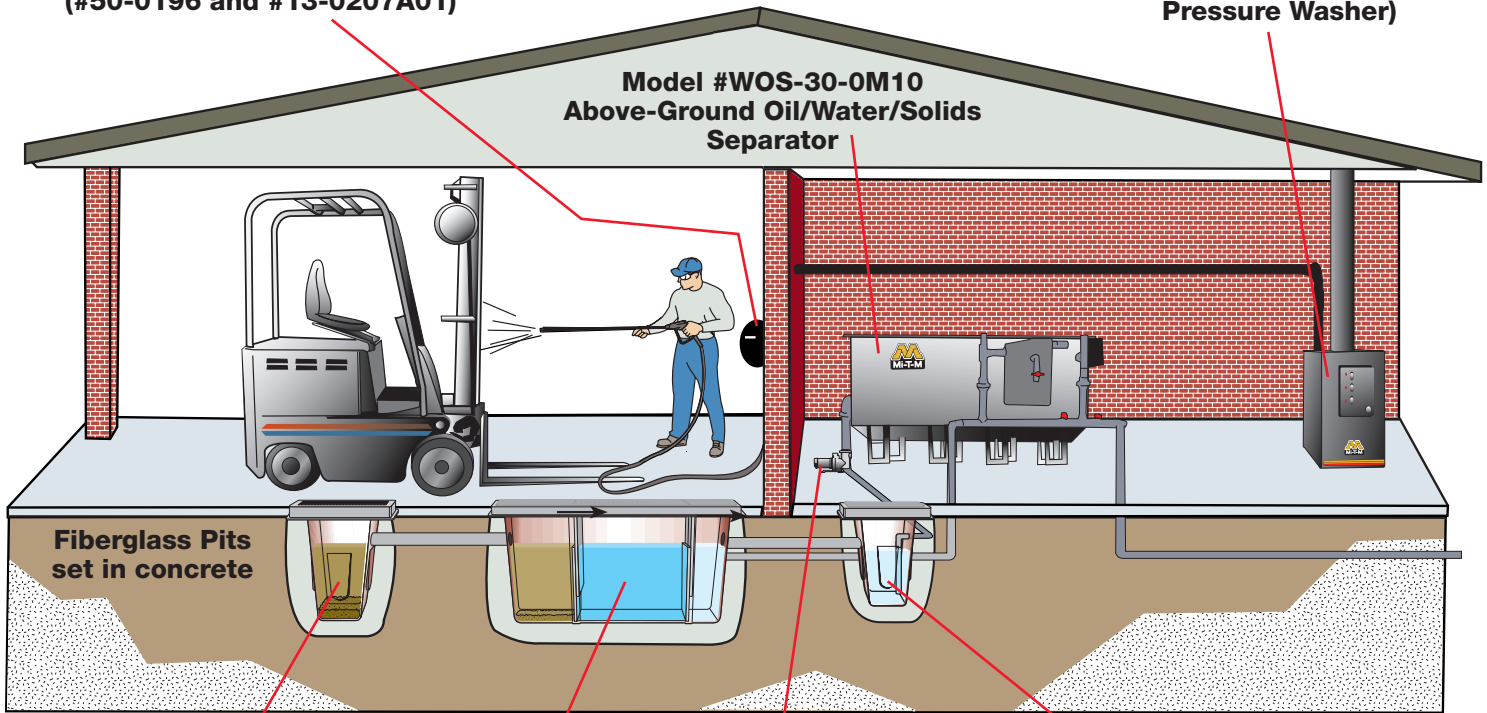

Fiberglass Pits set in concrete

**Model #12-0071
3' x 3' Fiberglass Catch Basin**

**Model #12-0074
3' x 9' Fiberglass 3-Stage Collection Pit**

**Model #3-0328
1.0 HP Surface-Mount Sump Pump Included with System**

**Model #12-0073
2' x 2' Fiberglass Sump Pit**

The WOS Series is perfect for the following applications:

- Rental Yards
- Heavy Equipment Dealers
- Trucking Facilities
- Military Bases
- Truck Rental Fleets
- Diesel Repair Facilities
- Forklift Washing Operations
- Aircraft Maintenance and Restoration
- Shipyards
- Municipalities/State DOTs
- Oil Fields
- Engine Rebuilders and Manufacturers

The Importance of a Proper Pit System

Once equipment is washed, the untreated wash water flows into your pit system. A proper pit system for your application is the first step in proper wash water treatment and a critical element in any wash water recycle system.

Consult Mi-T-M Corporation or your local distributor to determine the pit system configuration that works best for your application.

Mi-T-M designed the mechanical oil/water separator to remove free oils before discharging to your sanitary sewer. The oil/water separators will reduce the amount of suspended solids while removing hydrocarbons to meet stringent local sanitary sewer discharge requirements.

WCL Series Clarifier & Oil/Water Separators



CSA listed NEMA-4 rated corrosion-proof control panel for safe and reliable operation (WCL-30D-0M10 only)



Ozone generator for a "quick kill" of live bacteria on contact (WCL-30D-0M10 only)



WCL-30D-0M10

The WCL Series Offers The Following Features:

- A choice between a 300-gallon or 600-gallon cone-shaped tank for effective settling and easy handling of heavy solids
- Solids separation chamber with bag filter and decanting
- Oil skimmer and decanter for easy handling of oil
- CSA approved control panel which meets the requirements of the US and Canadian standards for an Industrial Control Panel
- 1.0 HP surface-mount sump pump



MODEL NUMBER	FLOW RATE	CLARIFIER TANK	OIL COALESCING AREA	POWER REQUIREMENTS	DIMENSIONS (LxWxH)	SHIP WT.
WCL-10S-0M10*+	0-10 GPM	300 gallons	48 sq. ft.	230V, 1Ø, 8.0A	48x67x97in.	641 lb.
WCL-30S-0M10*+	0-30 GPM	600 gallons	73 sq. ft.	230V, 1Ø, 8.0A	63x75x106in.	725 lb.
WCL-30D-0M10^	0-30 GPM	600 gallons	425 sq. ft.	230V, 1Ø, 13.0A	63x75x106in.	980 lb.

*Float consists of 230V plug.
^Ozone is included.

+ Control panel not included.
Surface-mount sump pump included on all models.

Accessories:

PART NUMBER	DESCRIPTION	FITS MODELS
855-0015	Treated-water storage tank - 80-gallons, for transferring water to the next process or point of discharge	All models
855-0016	Treated-water storage tank - 165-gallons, for transferring water to the next process or point of discharge	All models
RC-0005-0001	Mezzanine stand - For convenient access to the oil skimmer and to the top portion of the tank	WCL-30 models

Process & Flow Description

- 1. Clarifier Tank** - A 300-gallon or 600-gallon cone-shaped clarifier settles solids. Free-floating oils are removed via a suspended oil skimmer. Model WCL-30D-0M10 has 425 sq. ft. of oil coalescing media to help capture mechanically emulsified oil.
- 2. Electrical Control Panel** - CSA listed NEMA-4 rated corrosion-proof control panel for safe and reliable operation. (Standard on WCL-30D-0M10)
- 3. Corona Discharge Ozone Injection** - For odor control and breaking emulsified oils, the WCL-30D-0M10 comes with a corona discharge ozone generator. The ozone generator has an output of 0.5 grams per hour of ozone for "quick kill" of live bacteria on contact. Ozone also breaks up emulsified oils, allowing them to coalesce and float to the top of the tank for separation into the oil decanter.
- 4. Treated-Water Holding Tank** (Accessory #855-0015, 80-gallon capacity and #855-0016, 165-gallon capacity) - Treated-water holding tank for transferring water to the next process or point of discharge.
- 5. Solids Separation Chamber** - Solids from the wastewater stream settle at the base of the clarifier tank. With the opening of a single valve, solids are easily dropped into a bag filter in the solids separation chamber for effective capture and easy disposal. The bag filter is suspended on a dewatering tray with drainage returning to the in-ground collection pits.
- 6. Surface-Mount Sump Pump** - Untreated wash water is introduced into the system via a 1.0 HP surface-mount sump pump, which is included with the system.
- 7. Oil Decanter** - Oil skimmed from the surface of the clarifier tank is captured in a conveniently located oil decanter. Oil can be removed easily for appropriate disposal.
- 8. Mezzanine Stand** (Accessory #RC-0005-0001) - A maintenance ladder and platform is available for the WCL-30 Series for convenient access to the oil skimmer and to the top portion of the tank.



Sample Equipment Wash Pad Application

Remote Box for Pressure Washer with Hose Reel and Wall Mount Bracket (#50-0196 and #13-0207A01)

HEG-3004-0E2G (Electric Powered Natural Gas Fired Hot Water Pressure Washer)

Model #WCL-30D-0M10 Clarifier and Oil/Water Separator

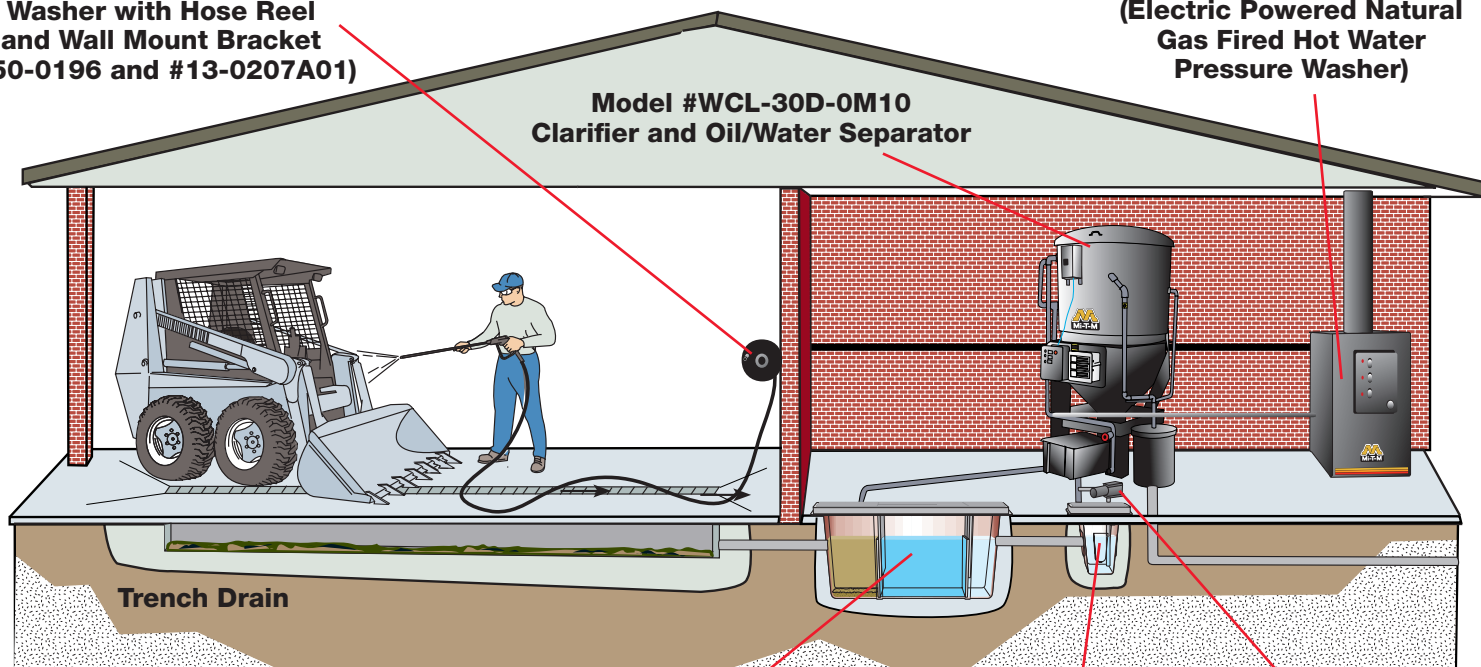

**Model #12-0074
3' x 9' Fiberglass
3-Stage Collection Pit**

**Model #12-0073
2' x 2' Fiberglass
Sump Pit**

**Model #3-0328
1.0 HP Surface-Mount
Sump Pump
Included with System**

The WCL Series is perfect for the following applications:

- Rental Yards
- Golf Courses
- Heavy Equipment Dealers
- Trucking Facilities
- Military Bases
- Truck Rental Fleets
- Diesel Repair Facilities
- Forklift Washing Operations
- Aircraft Maintenance and Restoration
- Shipyards
- Municipalities/State DOTs
- Oil Fields
- Engine Rebuilders and Manufacturers

The Importance of a Proper Pit System

Once equipment is washed, the untreated wash water flows into your pit system. A proper pit system for your application is the first step in proper wash water treatment and a critical element in any wash water recycle system.

Consult Mi-T-M Corporation or your local distributor to determine the pit system configuration that works best for your application.

In-Ground Fiberglass Pit Systems

PART NUMBER	PIT SIZE (FT.)	DESCRIPTION	SHIP WT.
12-0074	3x9x4.5	3-stage collection pit, fiberglass, 600-gallon capacity	480 lb.
12-0223	3x9x4.5	3-ft. x 9-ft. baffleless pit, fiberglass, 600-gallon capacity	480 lb.
12-0238	3x9x4.5	2-stage collection pit with single baffle, fiberglass, 600-gallon capacity	480 lb.
12-0244	3x9x4.5	3-stage collection pit with middle weir and third baffle, fiberglass, 600-gallon capacity, large solids settling area	480 lb.
20-0635A01	Fits 3x9	Above-ground external brace kit, #12-0074	250 lb.
56-0032	Fits 3x9	Aluminum hinged diamond plate cover with 3 frame sections	100 lb.
RC-0001-0003	Fits 3x9	Brace kit for installation of 3-stage collection pit	200 lb.
RC-0018-0001	Fits 3x9	Steel grating for pit; 3,060 lb./ft. ² uniform load rating	546 lb.
RC-0018-0002	Fits 3x9	Steel grating for pit with steel cover	680 lb.
12-0071	3x3x4.5	Catch basin, fiberglass, 100-gallon capacity	190 lb.
20-0480A01	Fits 3x3	Steel grating for pit, 2 sections; 6,250 lb./ft. ² uniform load rating, H-20 load rated	250 lb.
20-0733A01	Fits 3x3	Above-ground external brace kit	250 lb.
56-0031	Fits 3x3	Aluminum diamond plate cover with aluminum frame	30 lb.
RC-0001-0002	Fits 3x3	Brace kit for installation of 3-ft. x 3-ft. pit	150 lb.
12-0073	2x2x3	Sump pit, fiberglass, 50-gallon capacity	92 lb.
20-0479A01	Fits 2x2	Steel grating for pit; 6,660 lb./ft. ² uniform load rating, H-20 load rated	100 lb.
56-0030	Fits 2x2	Aluminum diamond plate cover with aluminum frame	60 lb.
RC-0001-0001	Fits 2x2	Brace kit for installation of 2-ft. x 2-ft. pit	75 lb.

Additional product information available in the Pit Systems Brochure.



3-stage collection pit

Cold & Hot Water Pressure Washers

Mi-T-M offers over 130 models of cold and hot water pressure washers, from hand carry and portable to stationary; direct drive and belt drive; electric, gasoline, diesel and natural gas.



*HHS Series
Hot Water Electric Powered
Oil-Heated Belt Drive*



*HEG Series
Hot Water Natural Gas/LP
Belt Drive*



*HVS Series
Hot Water Gasoline
Belt Drive*



*CW Premium Series
Cold Water Electric
Belt Drive*



*JP Series
Cold Water Gasoline
Direct Drive*



Mi-T-M Corporation
50 Mi-T-M Drive
Peosta, IA 52068
800-553-9053
563-556-1235 fax
corp@mitm.com
www.mitm.com

Performance Under Pressure.®

Distributed by: